

CHANCE® FOUNDATION SOLUTIONS

PRODUCT CATALOG

HELICAL PILES
AND ACCESSORIES



chancefoundationsolutions.com





DISCLAIMER

This catalog is provided as a guide to assist in product identification only. The information contained is for general information purposes only. The information is provided by Hubbell Power Systems, Inc. (“HPS”), and while we endeavor to keep the information up to date and correct, we make no representations or warranties of any kind, express or implied, about the completeness, accuracy, reliability, suitability or availability with respect to the catalog or the information, products, services, or related graphics contained in the catalog for any purpose. Any reliance you place on such information is therefore strictly at your own risk and HPS shall not be responsible for the adoption, revision, implementation, use or misuse of this information or its products herein. HPS recommends an independent engineering analysis of the installation (including soil and structure) conditions to determine the appropriate product for the intended use.

BUILDING CODE

Hubbell Power Systems, Inc. maintains an ICC Evaluation Service report ESR-2794 for the U.S. and for those jurisdictions who have adopted the International Building Code (IBC). This demonstrates that our systems have been independently evaluated by a third party administrator to ensure that our products meet building code requirements. With more ICC-ES certification reports than any other helical pile brand, you can design confidently with Chance products. Building code approved products numbers are noted throughout this catalog with a †. Learn more about our building code products by visiting our website using the URL or scanning the QR code.

<https://www.hubbell.com/chancefoundationsolutions/en/resources/technical-literature/building-code-reports>



Contact us:

Hubbell Power Systems, Inc.
210 North Allen Street
Centralia, MO 65240
Ph: (573) 682-5521
Email: civilconstruction@hubbell.com
www.chancefoundationsolutions.com

INTRODUCTION TO CHANCE® HELICAL PILES	4
SQUARE SHAFT (SS) PRODUCTS	5
Product Ratings and Cross Sections	5
1-1/4" to 2-1/4" Square Shaft Notes	5
SS125 (1-1/4")	6
SS5 (1-1/2")	8
SS150 (1-1/2")	10
SS175 (1-3/4")	12
SS200 (2")	13
SS225 (2-1/4")	14
ROCK-IT™ Helical Pile	15
Threaded Dywidag Adapters, Chain Shackles, Adapters	16
ROUND SHAFT (RS) PRODUCTS	18
Product Ratings and Cross Sections	18
2-7/8" to 8-5/8" Round Shaft Notes	18
RS2875.203 (2-7/8")	19
RS2875.276 (2-7/8")	21
RS3500.300 (3-1/2")	22
RS4500.337 (4-1/2")	24
RS5500.361 (5-1/2")	25
RS6625.280 (6-5/8")	26
RS7000.362 (7")	27
RS8625.250 (8-5/8")	28
SS/RS COMBINATION HELICAL PILES	30
HELICAL PULLDOWN® MICROPILE (HPM)	31
REMEDIAL REPAIR BRACKETS FOR HELICAL PILES	34
Standard Brackets	35
Low Profile Bracket and T-Pipe System	37
Direct Jack Bracket (DJ)	38
(Underpinning, Light Duty / Porch Bracket, Concrete Slab Bracket)	
Walkway Brackets	41
WALL ANCHOR SYSTEMS	44
Williams Form Wall Plate and Transition Kits	44
Wall Anchor Kits and Components	44
TERMINATION DEVICES FOR HELICAL PILES	46
New Construction Pile Caps	46
Dimensions and Ratings	47

INTRODUCTION TO CHANCE® HELICAL PILES

A helical pile is a segmented deep foundation system with helical bearing plates welded to a central steel shaft. The load is transferred from the shaft to the soil through bearing plates. Central steel shafts are available in either type SS (Square Shaft) series or type RS (Round Shaft) series. The type SS series are available in 1-1/4" to 2-1/4" square sizes. The type RS series are available in 2-7/8" to 8-5/8" diameter sizes. The type SS/RS combinations are also available for compression applications in soil conditions where dense/hard soils must be penetrated with softer/loose soils above the bearing strata. The Helical Pulldown® Micropile (HPM) series is also used in applications similar to those requiring the use of the type SS/RS combinations.

Please refer to the most recent edition of the Chance Technical Design Manual for:

- Complete list of mechanical rating and section properties of the central steel shafts
- Product feasibility
- Installation methodology for guidelines on the proper shaft section based on application, soil conditions, site accessibility, etc.

Segments or sections are joined with bolted couplings. Installation depth is limited only by soil density and practicality based on economics. A helical bearing plate or helix is one pitch of a screw thread. All helices, regardless of their diameter, have a standard 3" pitch. Being a true helical shape, the helices do not auger into the soil but rather screw into it with minimal soil disturbance. Helical plates are spaced at distances far enough apart that they function independently as individual bearing elements; consequently, the capacity of a particular helix on a helical pile shaft is not influenced by the helix above or below it.

Lead Section and Extensions

The first section or lead section contains the helical plates. This lead section can consist of a single helix or up to four helices. Additional helices can be added, if required, with the use of a helical extension. Standard helix sizes are shown in Table 1. The helices are arranged on the shaft such that their diameters increase as they get farther from the pilot point. The practical limits on the number of helices per pile is four to five if placed in a cohesive soil and six if placed in a cohesionless or granular soil.

Plain extensions are then added in standard lengths of 3.5, 5, 7, and 10 feet until the lead section penetrates into the bearing strata. Standard helix configurations are provided in the product series tables in this section. Note that lead time will be significantly reduced if a standard helix configuration is selected.

STANDARD HELIX SIZES - LEAD SECTIONS & EXTENSIONS, TABLE 1

HELIX DIAMETER in (cm)	6 (15)	8 (20)	10 (25)	12 (30)	14 (35)	16 (40)
AREA in ² (cm ²)	27 (172)	48 (312)	76 (493)	111 (716)	151 (974)	199 (1,286)

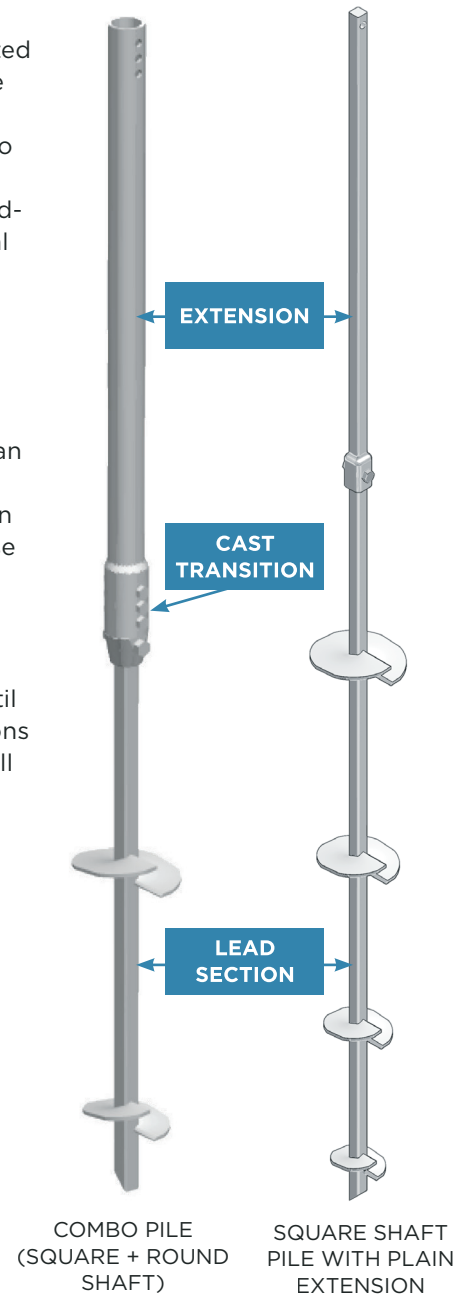

CHANCE® HELICAL SQUARE SHAFT PRODUCTS

PRODUCT RATINGS, TABLE 2

Product Series	Torque Rating Ft-lbs (Nm)	Ultimate Tension Strength* Kip (kN)	Uplift/Compression Capacity Limit** Kip (kN)
SS125	4,000 (5 400)	50 (222)	40 (178)
SS5	5,700 (7 730)	70 (312)	57 (254)
SS150	7,000 (9 500)	70 (312)	70 (312)
SS175	10,500 (14 240)	100 (445)	105 (467)
SS200	16,000 (21 700)	150 (668)	160 (712)
SS225	21,000 (28 470)	200 (890)	210 (934)

* Based on Mechanical Strength of Coupling

** Based on Torque Rating - Uplift/Compression Capacity Limit = Torque Rating x K_t
 "Default" K_t for Type SS = 10 ft-1 (33 m-1)
 Higher Compression Capacities Available with Helical Pulldown® Micropile

SS CROSS SECTIONS, TABLE 2B

Product Series	X Shaft Size Across Flats Inches (mm)	XY Diagonal Length Inches (mm)
SS125	1.25" (32)	1.66 (42)
SS5	1.5" (38)	1.91 (49)
SS150	1.5" (38)	1.91 (49)
SS175	1.75" (44)	2.27 (58)
SS200	2.0" (51)	2.57 (65)
SS225	2.25" (57)	2.93 (74)

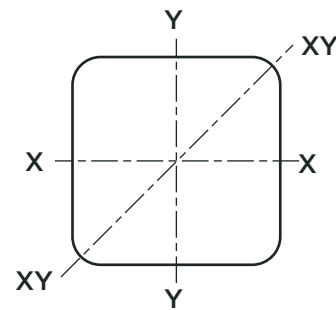

1-1/4" TO 2-1/4" SQUARE SHAFT NOTES

- Included connection hardware:
 - SS125 1-1/4" material: 5/8" diameter bolt per ASTM A325 type 1 and nut.
 - SS5 and SS150 1-1/2" material: 3/4" diameter bolt per ASTM A193 Grade B7 with cold weather properties and nut.
 - SS175 1-3/4" material: 7/8" diameter bolt per ASTM A193 Grade B7 and nut.
 - SS200 2" material: 1-1/8" diameter bolt per ASTM A193 Grade B7 and nut.
 - SS225 2-1/4" material: 1-1/4" diameter bolt per ASTM A193 Grade B7 and nut.
- Catalog numbers with an * after the number are lead sections that have been designed with a longer shaft above the top helix for the Chance® Helical Pulldown® Micropile.
- The letter "T" after the helix diameter stands for 1/2" thick helix material (otherwise common thickness is 3/8").
- All helices spaced three times the diameter of the preceding helix unless otherwise specified by customer.
- The standard helix has a sharpened leading edge.
- All products are hot dip galvanized per ASTM A153.
- For plain steel and/or special order items contact your area Chance distributor for availability.

SS125 (1-1/4") LEAD SECTIONS, TABLE 3

Catalog No.	Plate Diameter (in)			Nominal Length (ft)	Effective Length (in)*	Weight (lbs)	Helix Grade	Coating
	A	B	C					
C1500564	8	-	-	1	5.9	9	50	GALV
C1500545	8	-	-	5	60.0	33	50	GALV
C1500548	8	10	-	5	60.0	44	50	GALV
C1500551	8	10	12	5	60.1	58	50	GALV
C1500565	10	-	-	1	5.9	12	50	GALV
C1500546	10	-	-	5	60.0	36	50	GALV
C1500549	10	12	-	5	60.0	53	50	GALV
C1500552	10	12	14	7	79.0	78	50	GALV
C1500566	12	-	-	1	5.9	17	50	GALV
C1500547	12	-	-	5	60.0	40	50	GALV
C1500567	14	-	-	1	5.9	21	50	GALV
C1500601	14	-	-	5	60.0	43	50	GALV

* Effective length: from leading edge of bottom helix to center of the bolt hole.

SS125 (1-1/4") EXTENSIONS, TABLE 4

Catalog No.	Nominal Length (ft)	Effective Length (in)*	Weight (lbs)	Coating
C1500553	3.5	38.0	21	GALV
C1500554	5	57.8	30	GALV
C1500555	7	80.8	39	GALV
C1500556	10	117.3	54	GALV

* Effective length: from bolt hole to bolt hole. Contact your distributor for non-galvanized.

COMMON SS125 CONFIGURATIONS

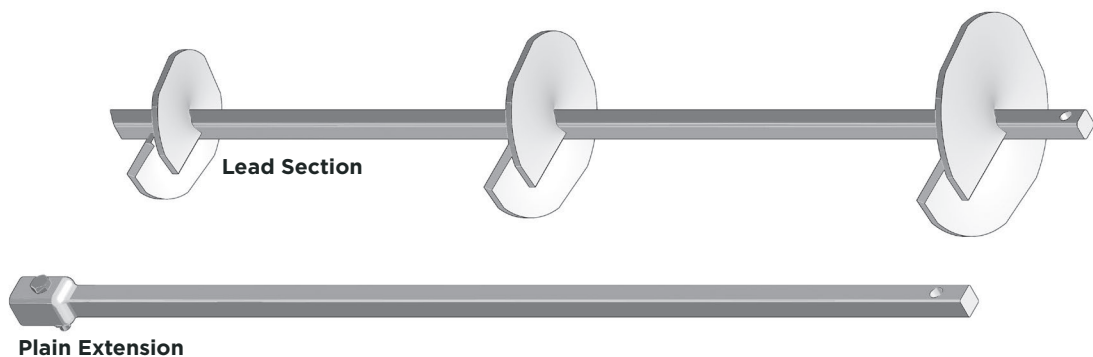

SS125 (1-1/4") SOIL NAIL LEAD SECTIONS & EXTENSIONS, TABLE 5

Type	Catalog No.	Helix Size	Number of Helices	Nominal Length (ft)	Effective Length (in)*	Length to First Helix (in)	Weight (lbs)	Helix Grade	Coating
Lead	C1500581	6	2	5	57.3	-	34	50	GALV
Lead	C1500582	8	2	5	57.3	-	38	50	GALV
Lead	C1500583	6	3	7	76.3	-	48	50	GALV
Lead	C1500584	8	3	7	76.3	-	52	50	GALV
Extension	C1500585	6	2	5	57.8	6	36	50	GALV
Extension	C1500586	8	2	5	57.8	6	40	50	GALV
Extension	C1500587	6	3	7	80.8	7	50	50	GALV
Extension	C1500588	8	3	7	80.8	7	54	50	GALV

* Effective length: from bolt hole to bolt hole. Contact your distributor for non-galvanized.

SS5 (1-1/2") SOIL NAIL LEAD SECTIONS & EXTENSIONS, TABLE 8

Type	Catalog No.	Helix Size	Number of Helices	Nominal Length (ft)	Effective Length (in)*	Length to First Helix (in)	Weight (lbs)	Helix Grade	Coating
Lead	C1100692	8	2	5	52.9	-	49	50	GALV
Lead	C1100691	8	3	7	77.9	-	69	50	GALV
Extension	C1100690	8	2	5	57.2	4-3/4"	51	50	GALV
Extension	C1100689	8	3	7	80.4	6-1/4"	71	50	GALV

* Effective length: from bolt hole to bolt hole. Contact your distributor for non-galvanized.

SS5/SS125 SOIL NAIL CONFIGURATIONS

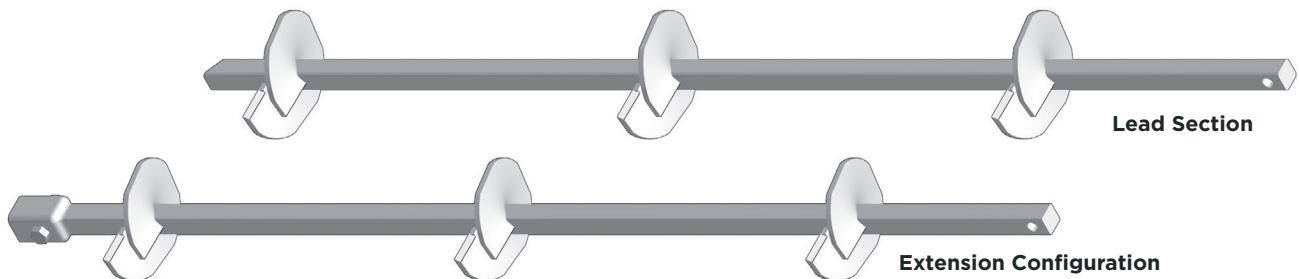



SS5 (1-1/2") LEAD SECTIONS, TABLE 6

Catalog No.	Plate Diameter (in)			Nominal Length (ft)	Effective Length (in)*	Weight (lbs)	Helix Grade
	A	B	C				
T1500086	6	6	-	3	29.7	49	50
C1500244	6	8	-	3	29.7	50	50
C1500030	6	8	-	7	76.2	64	50
C1500002 †	8	-	-	5	52.9	44	50
C1500001 †	8	-	-	7	76.2	56	50
C1500160 †	8	10	-	3	32.7	39	50
C1500006 †	8	10	-	7	76.2	70	50
C1500031 †	8	10	-	10	116.9	93	50
C1500007 †	8	10	12	5	60.2	68	50
C1500397 †	8	10	12	7	76.2	79	50
C1500058 †	10	-	-	5	52.9	47	50
C1500003 †	10	-	-	7	76.2	62	50
C1500161 †	10	12	-	3	38.9	55	50
C1500051 †	10	12	-	7	76.2	77	50
C1500489 †	10	12	14	7	76.2	93	50
C1500398	10	12	14	10	116.9	119	50
C1500242 †	12	-	-	5	52.9	52	50
C1500004 †	12	-	-	7	76.2	68	50
C150030	12	14	16	10	116.9	140	50
C1500243 †	14	-	-	5	52.9	55	50
C1500005 †	14	-	-	7	76.2	72	50
T1100607 †	14	14	-	7	76.2	95	50

* Effective length: from leading edge of bottom helix to center of bolt hole.

† ICC-ES Building code listed - see page 2 for more information.

SS5 (1-1/2") EXTENSIONS, TABLE 7

Catalog No.	Plate Diameter (A)	Nominal Length (ft)	Effective Length (in)*	Length to First Helix (in)	Weight (lbs)	Helix Grade	Coating
C1500047 †	-	3.5	37.4	-	28	-	GALV
C1500008 †	-	5	57.2	-	40	-	GALV
C1500009 †	-	7	80.2	-	57	-	GALV
C1500048 †	-	10	119.7	-	78	-	GALV
C1500166 †	14	3	37.4	47-1/4	55	80	GALV
T1500440	14	5	57.2	3-1/4	60	80	GALV
T15004402001	16	5	57.2	3-1/4	88	-	GALV

* Effective length: from bolt hole to bolt hole. Contact your distributor for non-galvanized.

† ICC-ES Building code listed - see page 2 for more information.

COMMON SS5 CONFIGURATIONS

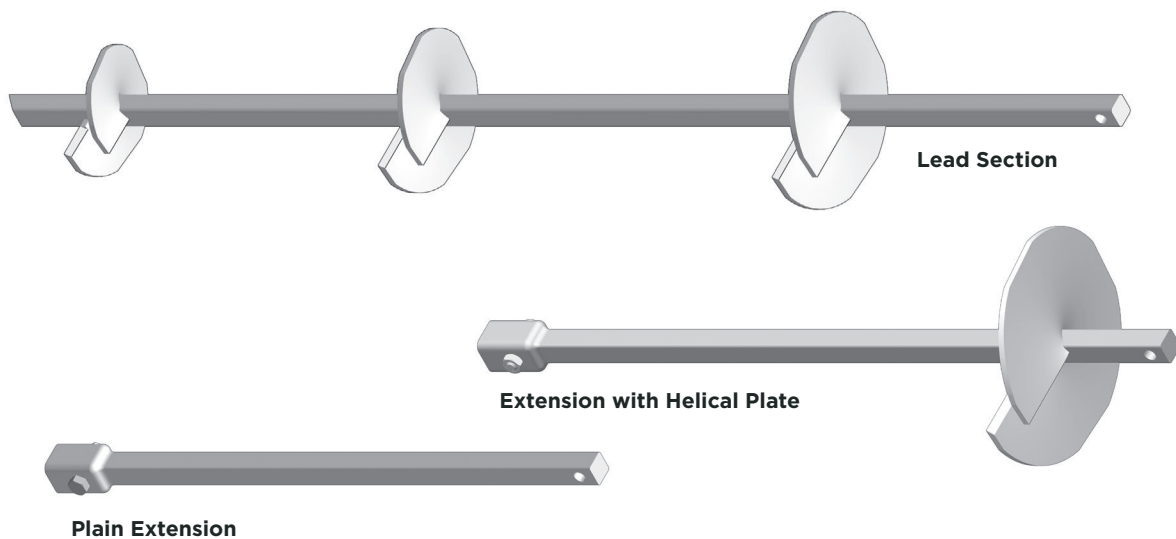



SS150 (1-1/2") LEAD SECTIONS, TABLE 9

Catalog No.	Plate Diameter (in)				Nominal Length (ft)	Effective Length (in)*	Weight (lbs)	Helix Grade
	A	B	C	D				
C1500400	6	8	10	-	7	76.2	70	80
C1500168	8	10	-	-	3	29.7	39	80
C1500472	8	10	-	-	5	57.2	57	80
C1500490	8	10	-	-	7	76.2	68	80
C1500169	8	10	12	-	5	60.2	67	80
C1501029	8	10	12	-	7	76.2	80	80
T1100521	8	10	12	14	10	116.9	127	80
C1500163	10	12	14	-	7	76.2	96	80
C1500165	10	12	14	14	10	116.9	143	80
C1500167	14	-	-	-	5	57.2	83	80
C1500170	14	14	14	-	10	116.9	135	80

* Effective length: from leading edge of bottom helix to center of bolt hole.

SS150 (1-1/2") EXTENSIONS, TABLE 10

Catalog No.	Plate Diameter (in)			Nominal Length (ft)	Effective Length (in)*	Length to First Helix (in)	Weight (lbs)	Helix Grade
	A	B	C					
C1500144	-	-	-	3	37.4	-	27	-
C1500145	-	-	-	5	57.2	-	41	-
C1500146	-	-	-	7	80.2	-	64	-
C1500175	-	-	-	10	127.2	-	81	-
C1500176	14	-	-	5	44.9	37	28	80
C1500177	14	14	-	7	80.2	37	93	80
C1500178	14	14	14	10	122.2	36	142	80

* Effective length: from bolt hole to bolt hole.

COMMON SS150 CONFIGURATIONS

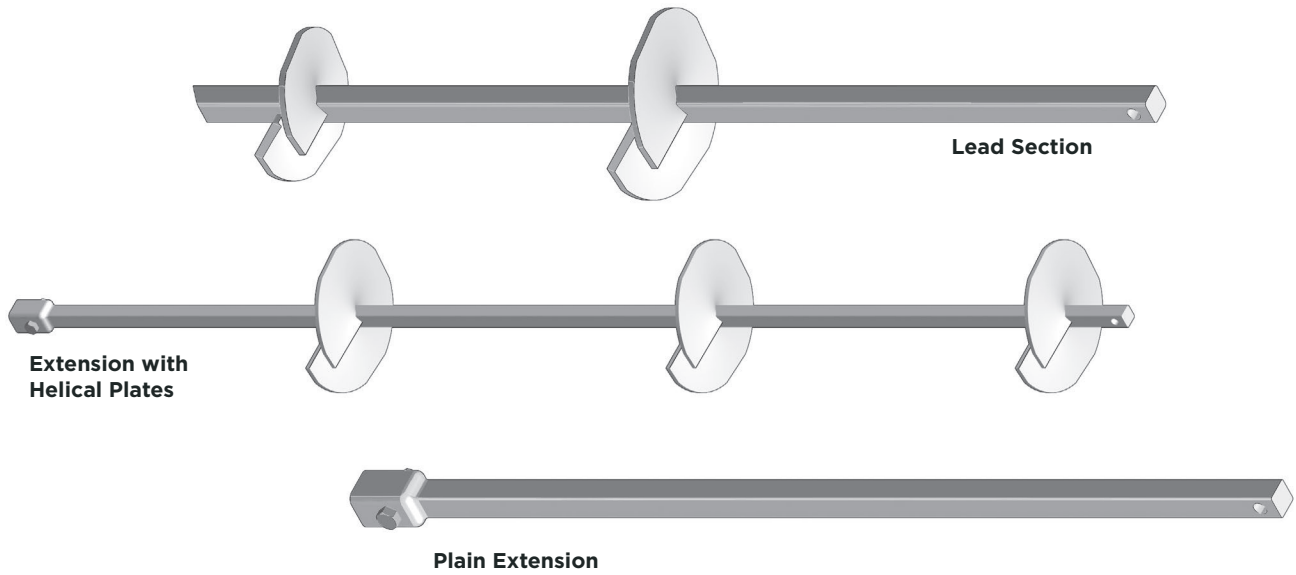

COMMON SS175 CONFIGURATIONS

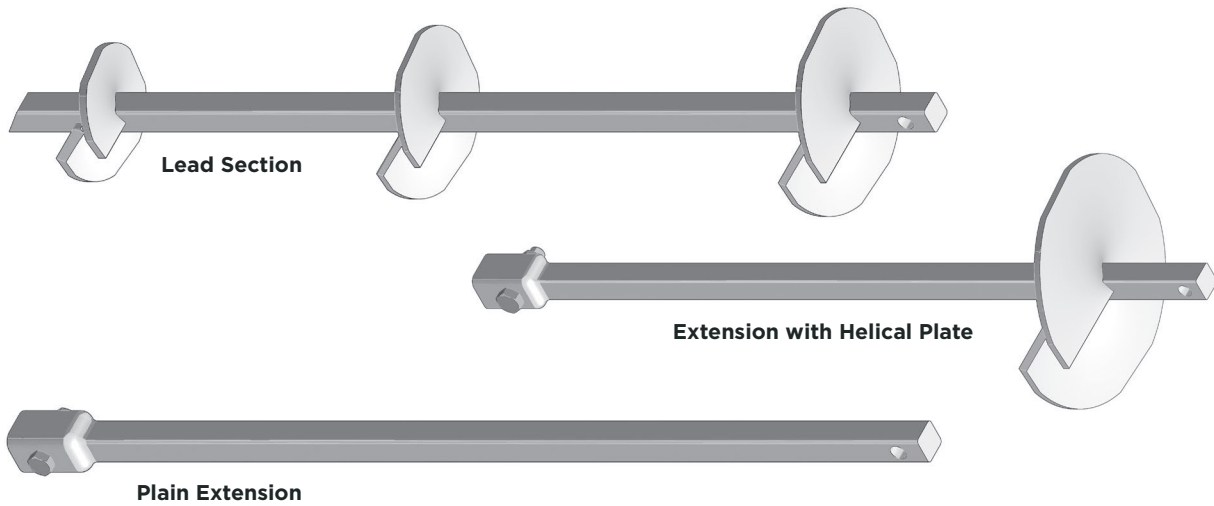



SS175 (1-3/4") LEAD SECTIONS, TABLE 11

Catalog No.	Plate Diameter (in)				Nominal Length (ft)	Effective Length (in)*	Weight (lbs)	Helix Grade
	A	B	C	D				
C1500010 †	8	-	-	-	5	57.8	60	80
C1500179 †	8	10	-	-	3	30.1	48	80
C1500012 †	8	10	-	-	5	57.8	71	80
C1500493 †	8	10	-	-	7	76.3	88	80
C1500180 †	8	10	12	-	5	57.8	82	80
C1500401 †	8	10	12	-	7	76.3	101	80
C1500986	8	10	12	-	10	122.3	146	80
C1100247 †	8	10	12	14	10	122.3	149	80
C1500093 †	10	12	-	-	5	57.8	79	80
C1502195 ††	10	12	14	-	7	76.3	116	80
C1500402 †	10	12	14	-	10	122.3	156	80
C1500181 †	14	14	14	-	10	122.3	158	80

* Effective length: from leading edge of bottom helix to center of bolt hole.

† ICC-ES Building code listed - see page 2 for more information.

†† Listed in the building code as T1100674

SS175 (1-3/4") EXTENSIONS, TABLE 12

Catalog No.	Plate Diameter (in)		Nominal Length (ft)	Effective Length (in)*	Length to First Helix (in)	Weight (lbs)	Helix Grade
	A	B					
C1500183 †	-	-	3.5	36.8	-	38	-
C1500013 †	-	-	5	58.3	-	56	-
C1500014 †	-	-	7	79.8	-	76	-
C1500184 †	-	-	10	123.1	-	112	-
C1500185 †	14	-	3	45.6	37	66	80
C1500470 †	14	-	5	58.3	4	80	80
C1500186 †	14	14	7	79.8	36	116	80

* Effective length: from bolt hole to bolt hole.

† ICC-ES Building code listed - see page 2 for more information.

SS200 (2") LEAD SECTIONS, TABLE 13

Catalog No.	Plate Diameter (in)				Nominal Length (ft)	Effective Length (in)*	Weight (lbs)	Helix Grade
	A	B	C	D				
C1502196	6T	8T	10T	-	5	59.2	97	80
C1502197	6T	8T	10T	12T	7	78.9	136	80
C1502198	8T	10T	12T	-	5	59.2	120	80
C1500403	8T	10T	12T	-	8	78.9	135	80
C1502199	8T	10T	12T		10	125.2	150	80
C1502200	8T	10T	12T	14T	10	125.2	213	80
C1502201	10T	12T	14T	-	7	78.9	147	80
C1500404	10T	12T	14T	-	10	125.2	212	80
C1100572	14T	14T	14T	-	10	125.2	228	80

* Effective length: from leading edge of bottom helix to center of bolt hole. "T" after plate diameter means 1/2" thick helix.

SS200 (2") EXTENSIONS, TABLE 14

Catalog No.	Plate Diameter (in)			Nominal Length (ft)	Effective Length (in)*	Length to First Helix (in)	Weight (lbs)	Helix Grade
	A	B	C					
C1502203	-	-	-	3	36.6	-	50	-
C1502204	-	-	-	5	58.6	-	75	-
C1502205	-	-	-	7	80.1	-	100	-
C1502206	-	-	-	10	123.2	-	150	-
C1502207	14T	-	-	3	45.6	35	78	80
C1502208	14T	14T	-	7	80.1	32	152	80
C1502209	14T	14T	14T	10	123.1	37-1/4	210	80

* Effective length: from bolt hole to bolt hole.

COMMON SS200 CONFIGURATIONS

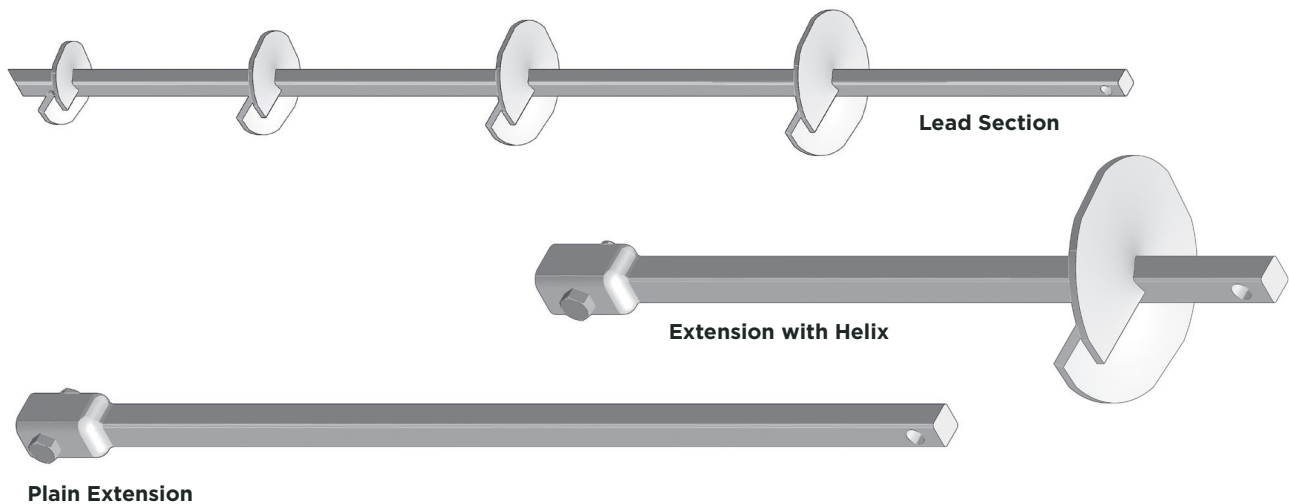

SS225 (2-1/4") LEAD SECTIONS, TABLE 15

Catalog No.	Plate Diameter (in)				Nominal Length (ft)	Effective Length (in)*	Weight (lbs)	Helix Grade
	A	B	C	D				
C1502210	6T	8T	10T	-	5	52.3	108	80
C1502211	8T	10T	12T	-	7	72.5	146	80
C1502212	8T	10T	12T	14T	10	112.8	230	80
C1502213	14T	14T	14T	-	10	112.8	250	80

* Effective length: from leading edge of bottom helix to center of bolt hole.
 "T" after plate diameter means 1/2" thick helix.

SS225 (2-1/4") EXTENSIONS, TABLE 16

Catalog No.	Plate Diameter (in)		Nominal Length (ft)	Effective Length (in)*	Length to First Helix (in)	Weight (lbs)	Helix Grade
	A	B					
C1502214	-	-	3	31.0	-	70	-
C1502215	-	-	5	52.1	-	88	-
C1502216	-	-	7	72.1	-	116	-
C1502217	-	-	9	111.0	-	175	-
C1502218	14T	-	5	52.1	24	79	80
C1502219	14T	14T	7	74.0	35-1/4	170	80

* Effective length: from bolt hole to bolt hole.
 "T" after plate diameter means 1/2" thick helix.

COMMON SS225 CONFIGURATIONS

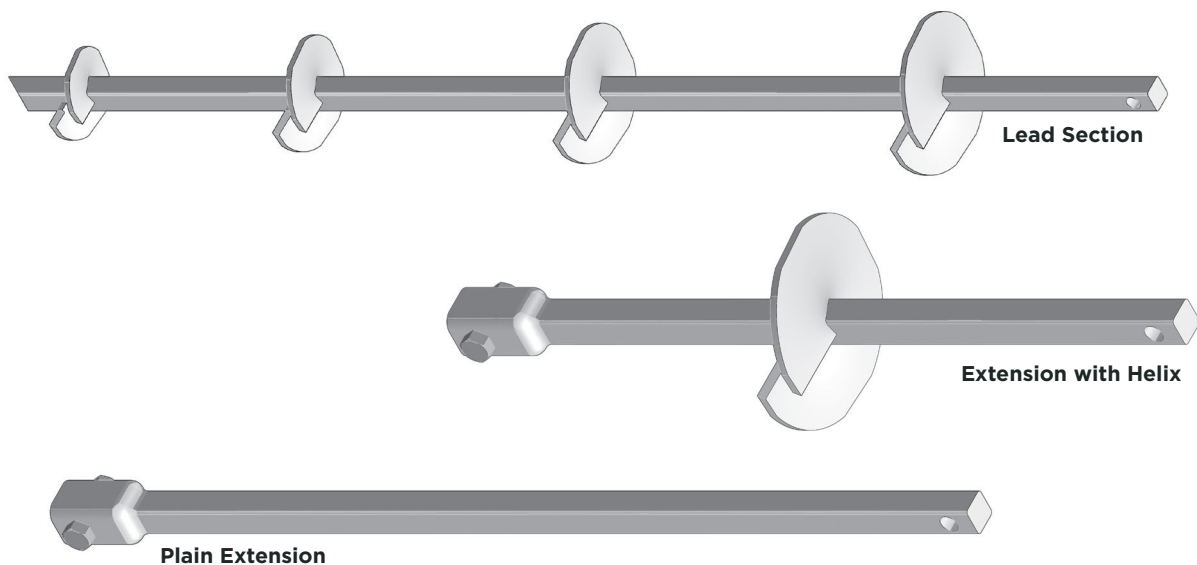

ROCK-IT™ Lead Section

The Chance® ROCK-IT™ lead section is an innovative solution to penetrate rocky or high blow count soils without pre-drilling or field modifications. The single carbide, patented design was developed to provide an economical, yet proven solution to reach load-bearing depths in high blow count material.

Learn more at <https://info.chancefoundationsolutions.com/rock-it>

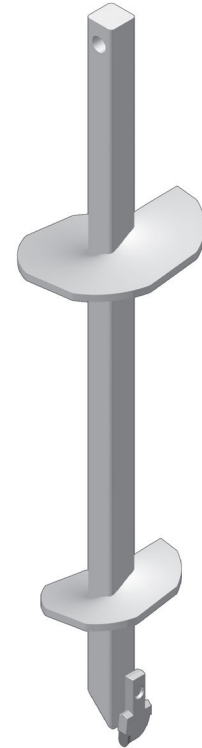

Some features of the ROCK-IT are:

- Reduced installation time to save time and money
- Wear resistant, offset carbide tip designed to break through rocky soil
- Reduced spiking of torque and chatter during installation for a safer alternative

ROCK-IT LEAD SECTIONS, TABLE 17

Catalog No.	Product Series	Plate Diameter (in)			Nominal Length (ft)	Effective Length (in)*	Weight (lbs)	Ultimate Capacity (kip)	Helix Grade
		A	B	C					
C1501488	SS150	6	8	-	3	31	36	70	80
C1501489	SS150	8	10	-	3	31	43	70	80
C1501505	SS150	8	10	-	5	59	60	70	80
C1501511	SS175	6	8	-	3	31	46	105	80
C1501513	SS175	8	10	-	3	31	54	105	80
C1501507	SS175	8	10	-	5	59	76	105	80
C1501509	SS175	8	10	12	5	59	94	105	80
C1501532	SS200	8	10	12	7	81.3	131	150	80
C1501544	SS225	8	10	12	7	74.7	140	200	80

* Effective length: from bolt hole to bolt hole.

Threaded Dywidag Adapters, Chain Shackles and Adapters

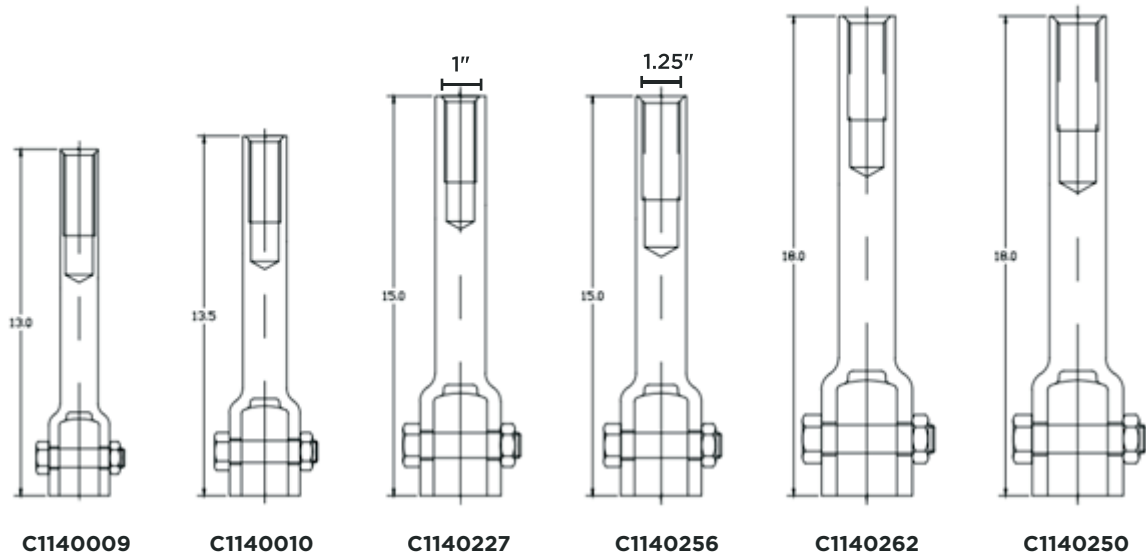

THREADED DYWIDAG ADAPTERS (WITH BOLTS AND NUTS), TABLE 18

Catalog No.	Product Series	Overall Length (in)	Weight (lbs)	Ultimate Capacity (kip)	Coating
C1101078*	SS5	9	7	70	GALV
C1140009	SS5/SS150	13	9	70	GALV
C1140010	SS175	13-1/2	16	100	GALV
C1140227	SS200	15	24	150	GALV
C1140256	SS200	15	20	150	GALV
C1140262	SS225	18	30	200	GALV
C1140250	SS225	18	30	200	GALV

* C1101078 is used with 1" standard all thread (not Dywidag)

CHAIN SHACKLES, TABLE 19

T1100134
C1100557
C1100558



C1100574

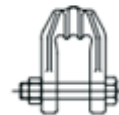

Catalog No.	Product Series	Description	Overall Length (in)	Weight (lbs)	Ultimate Capacity (kip)	Coating
C1100574	SS5/SS150	Tripeye Shackle	N/A	4	70	GALV
T1100134	SS175	Chain Shackle	6-5/8	6	100	GALV
C1100557	SS200	Chain Shackle	8.2	12	150	GALV
C1100558	S225	Chain Shackle	9	15	200	GALV

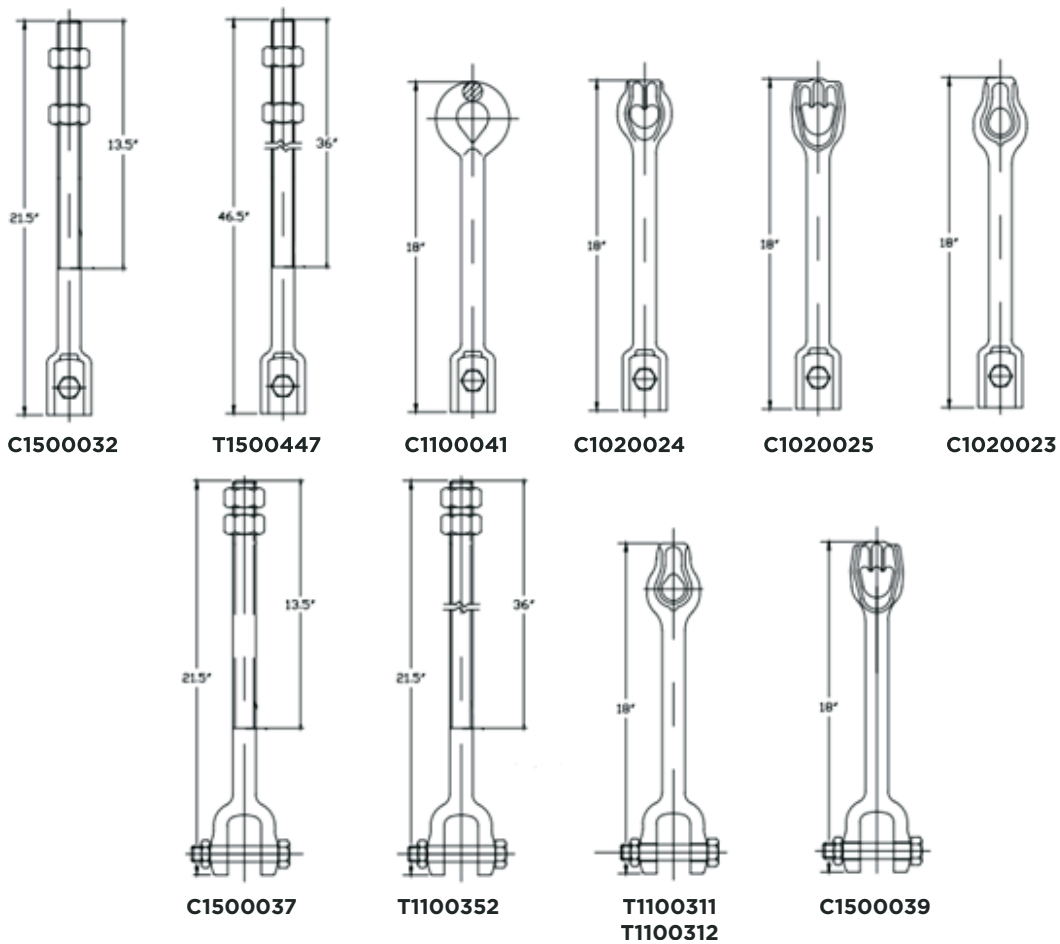

ADAPTERS, TABLE 20

Catalog No.	Product Series	Description	Overall Length (in)	Weight (lbs)	Ultimate Capacity (kip)	Coating
C1500580	SS125	Threaded Adapter	20	11	40	GALV
C1100041	SS5/SS150	Ovaleye	18	11	70	GALV
C1020023	SS5/SS150	Thimbleye	18	11	70	GALV
C1020024	SS5/SS150	Twineye	18	10	70	GALV
C1020025	SS5/SS150	Tripleye	18	10	70	GALV
C1500032	SS5/SS150	Threaded Adapter	21-1/2	11	70	GALV
T1500447	SS5/SS150	Threaded Adapter	46-1/2	19	70	GALV
C1500039*	SS175	Tripleye	18	11	100	GALV
T1100311*	SS175	Thimbleye	18	11	100	GALV
T1100352	SS175	Threaded Adapter	48	24	100	GALV
C1500037	SS175	Threaded Adapter	21-1/2	12	100	GALV
T1100312	SS200	Thimbleye	18	11	150	GALV
T1100629	SS200	Tripleye	18	11	150	GALV

* The 1-3/4" adapters have a clevis connection, not a forged coupling.



CHANCE® HELICAL ROUND SHAFT PRODUCTS

PRODUCT RATINGS AND CROSS SECTION DIMENSIONS, TABLE 21

Catalog No.	Torque Rating Ft-lbs (Nm)	Ultimate Tension Strength* Kip (kN)	Uplift/Compression Capacity Limit** Kip (kN)	X Diameter in (mm)	Y Wall Thickness in (mm)
RS2875.203	7,000 (9,500)	60 (267)	63 (280)	2.875 (73)	.203 (5.16)
RS2875.276	8,000 (10,800)	90 (400)	72 (320)	2.875 (73)	0.276 (7.01)
RS2875.276 †	8,900 (12,000)	98 (436)	80.1 (356)	2.875 (73)	0.276 (7.01)
RS3500.300	13,000 (17,600)	120 (534)	91 (405)	3.0 (76.2)	.300 (7.62)
RS3500.300 †	12,500 (17,000)	120 (534)	87.5 (389)	3.0 (76.2)	.300 (7.62)
RS4500.337 †	25,000 (31,200)	160 (712)	138 (614)	4.5 (114.3)	.337 (8.56)
RS6625.280	40,000 (54,200)	200 (890)	200 (890)	6.625 (168.3)	.280 (7.11)
RS8625.250	60,000 (81,300)	300 (1,334)	300 (1,334)	8.625 (219.08)	.250 (6.35)

* Based on mechanical strength of coupling

** Based on torque rating - uplift/compression capacity limit = torque rating x K_t
 "Default" K_t for type RS2875 Series = 9 ft-1 (30 m-1); for type RS3500.300 = 7 ft-1 (23 m-1); for type RS4500.337 = 6 ft-1 (20 m-1); for type RS6625.280 = 5 ft-1 (13 m-1); for type RS8625.250 = 5 ft-1 (13 m-1).

*** Product evaluated per AC308 for Building Code compliance, see ICC-ES ESR-2794.

† ICC-ES Building code listed - see page 2 for more information.

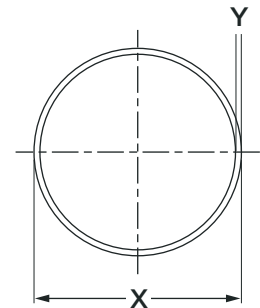

2-7/8" TO 8-5/8" ROUND SHAFT NOTES

- Included Connection Hardware:
 - RS2875.203 2-7/8" diameter material: (2) 3/4" x 4-1/4" bolt per SAE J429 Grade 5 and nuts.
 - RS2875.276 2-7/8" diameter material: (2) 3/4" x 4-1/4" bolt per SAE J429 Grade 5 and nuts.
 - RS3500.300 3-1/2" diameter material: (3) 3/4" x 5-3/4" bolt per SAE J429 Grade 5 and nuts.
 - RS4500.337 4-1/2" diameter material: (2) 1" x 5-1/2" bolt per SAE J429 Grade 8 and nuts.
 - RS6625.280 6" diameter material: (4) 1" x 8" threaded stud and nuts.
 - RS8625.250 8" diameter material: (4) 1-1/4" x 10-1/2" threaded stud and nuts.
- The letter "T" after the helix diameter stands for 1/2" thick helix material.
- All helices are spaced three times the diameter of the preceding helix unless otherwise specified by the customer.
- All products are hot dip galvanized per ASTM A153.
- For plain steel and/or special order items contact your area Chance® distributor for availability.

RS2875.203 (2-7/8") LEAD SECTIONS, TABLE 22

Catalog No.	Plate Diameter (in)			Nominal Length (ft)	Effective Length (in)*	Weight (lbs)	Helix Grade
	A	B	C				
C2784765 †	8	-	-	7	76.3	44	50
C2784512	8	10	-	5	56.5	45	50
C2784513	8	10	-	7	76.3	57	50
C2784514 †	8	10	12	5	56.5	53	50
C2784773 †	8	10	12	7	76.3	66	50
C2784510	10	-	-	5	58.5	38	50
C2784519	10	-	-	7	76.3	48	50
C2784767 †	10	-	-	7	76.3	48	50
C2784505	10	12	-	5	56.5	53	50
C2784772 †	10	12	-	7	76.3	63	50
C2784774 †	10	12	14	7	76.3	78	50
C2784508	10	12	14	10	188.3	122	50
C2784503	12	-	-	5	56.5	46	50
C2784509 †	12	-	-	7	76.3	54	50
C2784511 †	14	-	-	7	76.3	57	50
C2784515	14	-	-	10	118.3	100	50

* Effective length: from leading edge of bottom helix to center of the bolt hole.

† ICC-ES Building code listed - see page 2 for more information.

RS2875.203 (2-7/8") EXTENSIONS, TABLE 23

Catalog No.	Plate Diameter (in)		Nominal Length (ft)	Effective Length (in)*	Length to First Helix (in)	Weight (lbs)	Helix Grade
	A	B					
C2784300CU	-	-	3.5	36.0		23	
C2784760 †			3.5	36.0		23	
C2784500CU	-	-	5	57.0		32	
C2784761 †			5	57.0		32	
C2784700CU	-	-	7	78.3		43.5	
C2784762 †			7	78.3		43.5	
C27841000CU	-	-	10	120.0		61	
C2784763 †			10	120.0		61	
C2784782 †	14	-	3.5	36.0	24.0	41	50
C2784501CU	14	-	5	57.0	30.0	70	50
C2784502CU	14	14	7	78.0	30.0	75	50

* Effective length: from bolt hole to bolt hole.

CU in catalog number indicates cold upset vs. welded coupling.

† ICC-ES Building code listed - see page 2 for more information.

COMMON 2875.203 CONFIGURATIONS

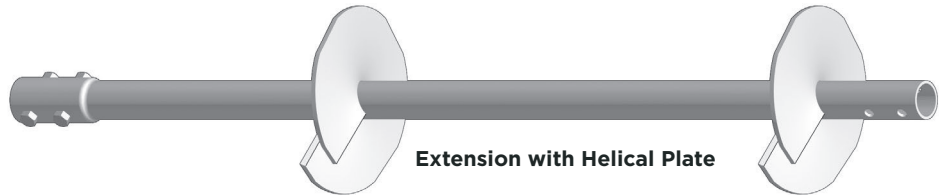
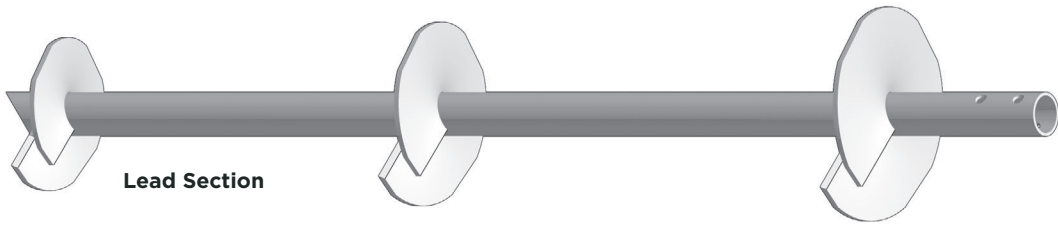

COMMON RS2875.276 CONFIGURATIONS

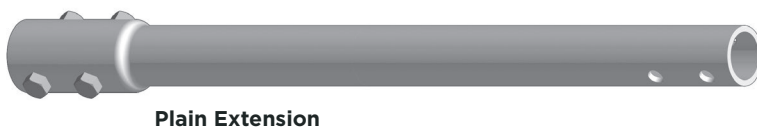
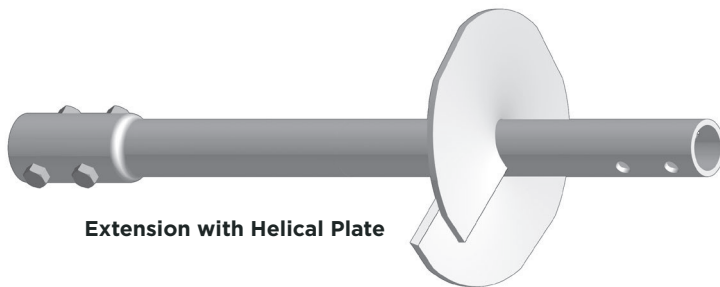
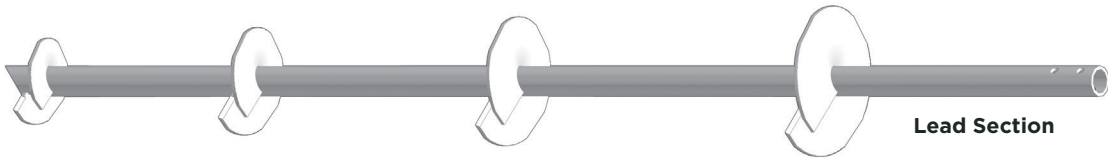

RS2875.276 (2-7/8") LEAD SECTIONS, TABLE 25

Catalog No.	Plate Diameter (in)				Nominal Length (ft)	Effective Length (in)*	Weight (lbs)	Helix Grade
	A	B	C	D				
C2788188	8	-	-	-	3.5	34.3	32	80
C2788007 †	8	10	-	-	5	56.3	50	80
C2788002 †	10	-	-	-	5	56.3	48	80
C2788003 †	10	12	-	-	5	56.3	60	80
C2788191	12	-	-	-	5	56.3	63	80
C2788008	8	-	-	-	7	76.3	55	80
C2788210 †	8	-	-	-	7	79.0		
C2788004 †	8	10	12	-	7	76.3	80	80
C2788184	10	-	-	-	7	76.3	48	80
C2788001 †	10	-	-	-	7	76.3	59	80
C2788009 †	10	12	-	-	7	76.3	71	80
C2788005 †	10	12	14	-	7	76.3	83	80
C2788221 †	12	-	-	-	7	79.0		
C2788222 †	14	-	-	-	7	79.0		
T1071312 †	8	-	-	-	10	121.0		
C2788006 †	8	10	12	14	10	118.3	128	80
C2788179 †	10	12	14	14	10	118.3	134	80

* Effective length: from leading edge of bottom helix to center of the bolt hole.

† ICC-ES Building code listed - see page 2 for more information.

RS2875.276 (2-7/8") EXTENSIONS, TABLE 26

Catalog No.	Plate Diameter (in)	Nominal Length (ft)	Effective Length (in)*	Weight (lbs)	Helix Grade
C2788300CU	-	3.5	36	28	-
C2788225 †	-	3.5	36	28	-
C2788314CU	14	3.5	36	54	80
C2788228 †	14	3.5	36	54	80
C2788500CU	-	5	57	42	-
C2788218 †	-	5	57	43	-
C2788700CU	-	7	78	56	-
C2788219 †	-	7	78	55	-
C27881000CU	-	10	120	79	-
C2788220 †	-	10	120	78	-

* Effective length: from bolt hole to bolt hole.

CU in catalog number indicates cold upset vs. welded coupling.

† ICC-ES Building code listed - see page 2 for more information.



RS3500.300 (3-1/2") LEAD SECTIONS, TABLE 28

Catalog No.	Plate Diameter (in)				Nominal Length (ft)	Effective Length (in)*	Weight (lbs)	Helix Grade
	A	B	C	D				
C1070560	8T	10T	-	-	3	33.3	50	50
C1070563 †	8T	10T	12T	-	7	74.5	103	50
C1070566 †	8T	10T	12T	14T	10	117.3	145	50
T1070813 †	10T	-	-	-	7	74.5	78	50
C1070561	10T	12T	-	-	5	41.3	65	50
C1500023 †	10T	12T	-	-	7	74.5	97	50
T1070812 †	10T	12T	-	-	10	117.3	121	50
C1070564 †	10T	12T	14T	-	7	75.5	113	50
C1070567 †	10T	12T	14T	14T	10	117.3	180	50
C1500021 †	12T	-	-	-	7	75.5	73	50
C1070565 †	12T	14T	14T	-	10	117.3	170	50
C1070568 †	12T	14T	14T	14T	10	117.3	185	50
C1500022 †	14T	-	-	-	7	75.5	75	50

* Effective length: from leading edge of bottom helix to center of the bolt hole.

† ICC-ES Building code listed - see page 2 for more information.

RS3500.300 (3-1/2") EXTENSIONS, TABLE 29

Catalog No.	Plate Diameter (in)		Nominal Length (ft)	Effective Length (in)*	Weight (lbs)	Helix Grade
	A	B				
C1070573CU	-	-	3.5	35	40	-
C1501291 †	-	-	3.5	38	39	-
C1500025CU	-	-	5	56	60	-
C1501240 †	-	-	5	56	54	-
C1500026CU	-	-	7	77	77	-
C1501241 †	-	-	7	80	75	-
C1500216CU	-	-	10	119	115	-
C1501242 †	-	-	10	116	102	-
C1501293 †	14	-	3.5	38	87	50
C1070577CU	14T	-	5	56	81.5	50
C1501295 †	14	14	7	80	122	50
C1070579CU	14T	14T	7	77	122	50

* Effective length: from bolt hole to bolt hole.

CU in catalog number indicates cold upset vs. welded coupling

"T" after plate diameter means 1/2" thick helix (otherwise common thickness is 3/8").

† ICC-ES Building code listed - see page 2 for more information.

COMMON RS3500.300 CONFIGURATIONS

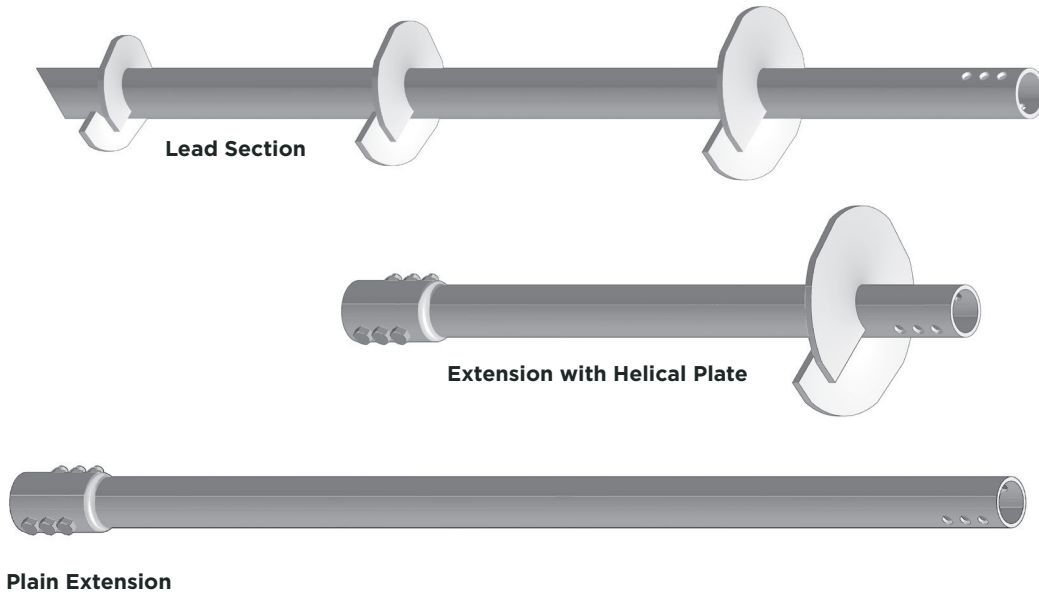

COMMON RS4500.337 CONFIGURATIONS

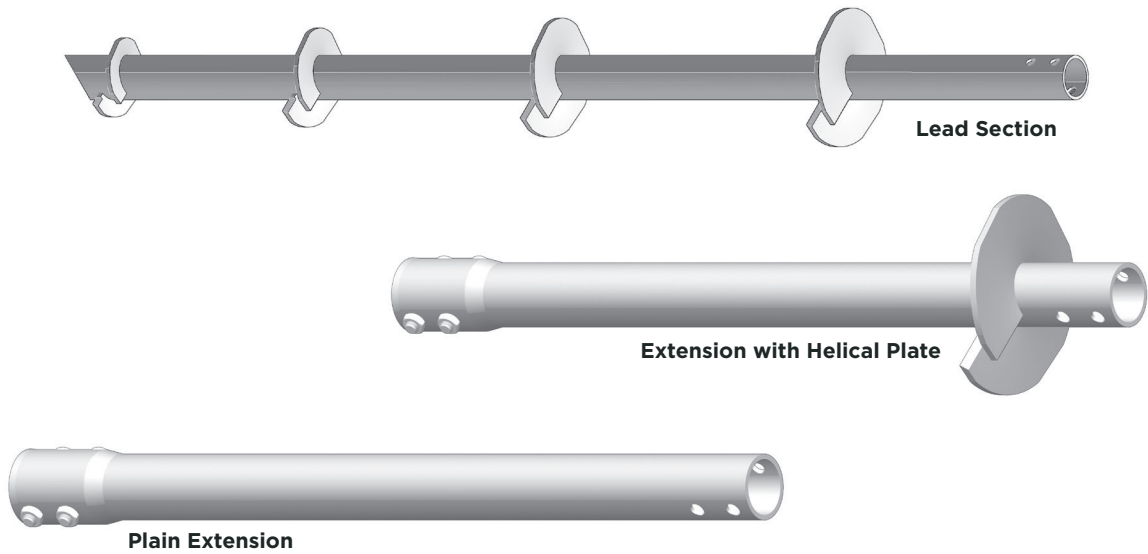



RS4500.337 (4-1/2") LEAD SECTIONS, TABLE 31

Catalog No.	Plate Diameter (in)				Nominal Length (ft)	Effective Length (in)*	Weight (lbs)	Helix Grade
	A	B	C	D				
C1070917 †	8T	-	-	-	7	74.5	103	80
C1070889 †	8T	10T	12T	-	7	74.5	130	80
C1070890 †	8T	10T	12T	14T	10	115.5	195	80
C1070976 †	10T	-	-	-	7	74.5	111	80
C1071799 †	10T	12T	-	-	7	74.5	122	80
C1070943 †	10T	12T	14T	-	7	73.5	158	80
C1070892 †	10T	12T	14T	14T	10	115.5	204	80
C1072703 †	12T	-	-	-	7	74.5	114	80
C1071995 †	14T	-	-	-	7	74.5	119	80

* Effective length: from leading edge of bottom helix to center of the bolt hole.
 "T" after plate diameter means 1/2" thick helix (otherwise common thickness is 3/8").
 † ICC-ES Building code listed - see page 2 for more information.

RS4500.337 (4-1/2") EXTENSIONS, TABLE 32

Catalog No.	Plate Diameter (in)	Nominal Length (ft)	Effective Length (in)*	Weight (lbs)	Helix Grade
C1072466CU †	-	3.5	36	77	-
C1072467CU †	-	5	57	101	-
C1072468CU †	-	7	78	124	-
C1072469CU †	-	10	120	175	-
C1070886CU †	14T	5	57	125	80

* Effective length: from bolt hole to bolt hole.
 "T" after plate diameter means 1/2" thick helix (otherwise common thickness is 3/8").
 † ICC-ES Building code listed - see page 2 for more information.

RS5500.361 HIGH CAPACITY PILES, TABLE 33

Catalog No.	Description	Plate Diameter (in)				Nominal Length (ft)	Effective Length (in)*	Weight (lbs)	Helix Grade
		A	B	C	D				
C1073173	LEAD, RS5500.361, 14 X 10FT SC HCP	14T				10	103	216.8	50
C1073150	LEAD, RS5500.361, 16 X 10FT SC HCP	16T				10	103	223.5	50
C1073155	LEAD, RS5500.361, 12/14 X 10FT SC HCP	12T	14T			10	103	229.4	50
C1073156	LEAD, RS5500.361, 14/14 X 10FT SC HCP	14T	14T			10	103	235.2	50
C1073157	LEAD, RS5500.361, 16/16 X 10FT SC HCP	16T	16T			10	103	248.6	50
C1073158	LEAD, RS5500.361, 16/18 X 10FT SC HCP	16T	18T			10	103	264.4	50
C1073167	LEAD, RS5500.361, 12/14/16 X 10FT SC HCP	12T	14T	16T		10	103	268.3	50
C1073174	LEAD, RS5500.361, 14/16/18 X 10FT SC HCP	14T	16T	18F		10	103	282.8	50
C1073159	EXTENSION, RS5500.361, 3.5FT, GALV HCP					3.5	31	107.6	
C1073160	EXTENSION, RS5500.361, 5FT, GALV HCP					5	49	137.4	
C1073161	EXTENSION, RS5500.361, 7FT, GALV HCP					7	73	199	
C1073162	EXTENSION, RS5500.361, 10FT, GALV HCP					10	109	270.7	
C1073163	EXTENSION, RS5500.361, 15FT, GALV HCP					15	169	335.7	
C1073164	EXTENSION, RS5500.361, 21FT, GALV HCP					21	241	454.7	
C1073175	EXTENSION, RS5500.361, 16 X 5FT 6SC HCP	16T				5	49	192.7	50
C1073176	EXTENSION, RS5500.361, 18 X 5FT 6SC HCP	18F				5	49	178.3	50

"T" after plate diameter means 1/2" thick helix
 "F" after plate diameter means 5/8" thick helix
 Helix Pitch for RS5500 is 6 inches.



RS6625.280 (6-5/8") LEAD SECTIONS, TABLE 35

Catalog No.	Coupling	Plate Diameter (in)			Nominal Length (ft)	Effective Length (in)*	Helix Grade	Pitch (in)	Coating
		A	B	C					
T1071365	Box	14	16	-	10	274	50	3	GALV
T1072037	Box	14	16	-	10	274	50	6	GALV
T1072038	Box	14	16	18	10	313	50	3	GALV
T1072039	Box	14	16	18	10	313	50	6	GALV
T1071568	Plate	14	16	-	10	274	50	3	GALV
T1072048	Plate	14	16	-	10	274	50	6	GALV
T1072049	Plate	14	16	18	10	313	50	3	GALV
T1072050	Plate	14	16	18	10	313	50	6	GALV

* Effective length: from leading edge of bottom helix to center of the bolt hole.

RS6625.280 (6-5/8") EXTENSIONS, TABLE 36

Catalog No.	Coupling	Pitch Diameter (in)	Nominal Length (ft)	Weight (lbs)	Helix Grade	Pitch (in)	Coating
T1072044	Box	18	10	285	50	3	GALV
T1072045	Box	18	10	285	50	6	GALV
C1070969	Box	-	5	141	50	-	GALV
C1070973	Box	-	10	246	50	-	GALV
T1072054	Plate	18	10	285	50	3	GALV
T1072055	Plate	18	10	285	50	6	GALV
T1071537	Plate	-	5	141	50	-	GALV
T1071536	Plate	-	10	246	50	-	GALV

* Effective length: from bolt hole to bolt hole.

RS7000.362 (7") HIGH CAPACITY PILES, TABLE 34

Catalog No.	Description	Plate Diameter (in)			Nominal Length (ft)	Effective Length (in)*	Weight (lbs)	Helix Grade
		A	B	C				
C1073128	LEAD, RS7000.362, 16 X 10FT SC HCP	16T			10	107.5	285.9	50
C1073129	LEAD, RS7000.362, 18 X 10FT SC HCP	18F			10	107.5	295.5	50
C1073130	LEAD, RS7000.362, 24 X 10FT SC HCP	24F			10	107.5	330.8	50
C1073117	LEAD, RS7000.362, 16/16 X 10FT SC HCP	16T	16T		10	107.5	325.3	50
C1073131	LEAD, RS7000.362, 18/18 X 10FT SC HCP	18F	18F		10	107.5	334.1	50
C1073132	LEAD, RS7000.362, 24/24 X 10FT SC HCP	24F	24F		10	107.5	404.8	50
C1073133	LEAD, RS7000.362, 16/18 X 10FT SC HCP	16T	18F		10	107.5	324.5	50
C1073134	LEAD, RS7000.362, 16/24 X 10FT SC HCP	16T	24F		10	107.5	359.9	50
C1073136	LEAD, RS7000.362, 16/20 X 10FT SC HCP	16T	20F		10	107.5	335.2	50
C1073140	LEAD, RS7000.362, 16/20 X 21FT SC HCP	16T	20F		21	239.5	617.7	50
C1073181	LEAD, RS7000.362, 18/20 X 10FT SC HCP	18F	20F		10	107.5		50
C1073182	LEAD, RS7000.362, 16/18/20 X 10FT SC HCP	16T	18F	20F	10	107.5		50
C1073124	EXTENSION, RS7000.362, 3.5FT, GALV HCP				3.5	42	138.9	
C1073125	EXTENSION, RS7000.362, 5FT, GALV HCP				5	60	178.5	
C1073126	EXTENSION, RS7000.362, 7FT, GALV HCP				7	84	211.3	
C1073118	EXTENSION, RS7000.362, 10FT, GALV HCP				10	120	303.8	
C1073127	EXTENSION, RS7000.362, 15FT, GALV HCP				15	15	440.8	
C1073138	EXTENSION, RS7000.362, 21FT, GALV HCP				21	252	612.9	
C1073177	EXTENSION, RS7000.362, 20 X 5FT, GALV HCP	20F			5	60		50
C1073178	EXTENSION, RS7000.362, 22 X 7FT, GALV HCP	22F			7	84		50
C1073179	EXTENSION, RS7000.362, 24 X 7FT, GALV HCP	24F			7	84		50
C107315	EXTENSION, RS7000.362, 26 X 7FT, GALV HCP	26F			7	84		50

"T" after plate diameter means 1/2" thick helix
 "F" after plate diameter means 5/8" thick helix
 Helix Pitch for RS7000 is 6 inches



RS8625.250 (8-5/8") LEAD SECTIONS, TABLE 37

Catalog No.	Coupling	Plate Diameter (in)			Nominal Length (ft)	Weight (lbs)	Helix Grade	Pitch (in)	Coating
		A	B	C					
T1072040	Box	16	18	-	10	326	50	3	GALV
T1072041	Box	16	18	-	10	326	50	6	GALV
T1072042	Box	16	18	20	10	371	50	3	GALV
T1072043	Box	16	18	20	10	371	50	6	GALV
T1072051	Plate	16	18	-	10	325	50	3	GALV
T1071848	Plate	16	18	-	10	325	50	6	GALV
T1072052	Plate	16	18	20	10	370	50	3	GALV
T1072053	Plate	16	18	20	10	370	50	6	GALV

* Effective length: from leading edge of bottom helix to center of the bolt hole.

RS8625.250 (8-5/8") EXTENSIONS, TABLE 38

Catalog No.	Coupling	Plate Diameter (in)	Nominal Length (ft)	Weight (lbs)	Helix Grade	Pitch (in)	Coating
T1072046	Box	20	10	341	50	3	GALV
T1072047	Box	20	10	341	50	6	GALV
C1070956	Box	-	5	172	-	-	GALV
C1070906	Box	-	10	296	-	-	GALV
T1072056	Plate	20	10	339	50	3	GALV
T1072057	Plate	20	10	339	50	6	GALV
T1071564	Plate	-	10	170	-	-	GALV
T1071849	Plate	-	10	294	-	-	GALV

* Effective length: from bolt hole to bolt hole.

COMMON RS6625.280 AND RS8628.250 COUPLING CONFIGURATIONS

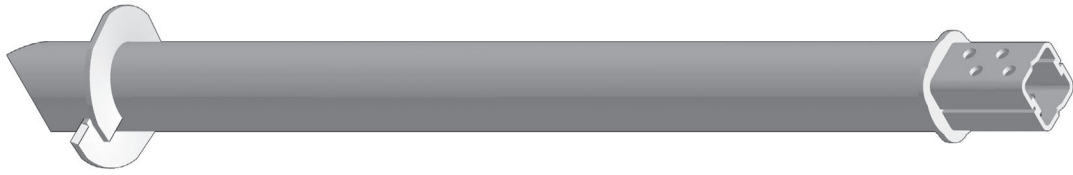

Lead Section with Box Coupler

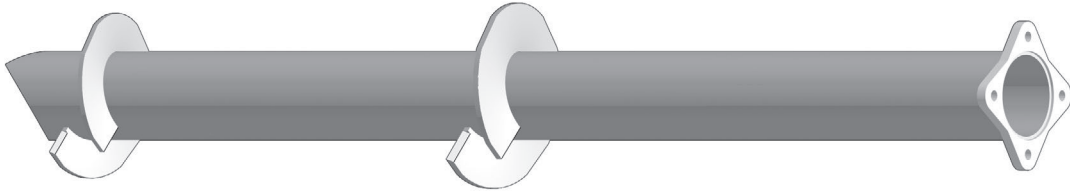

Lead Section with Plate Coupler



Extension Section with Box Coupler



Extension Section with Plate Coupler

SS/RS COMBINATION HELICAL PILES

Helical Transition Coupler Adapts Type SS to Type RS Pile Shafts

The type SS/RS combination piles are used mainly in compression applications in areas where soft/loose soils are located above the bearing strata (hard/dense soils) for the helices. The type RS material with a much greater section modulus will resist columnar buckling in the soft/loose soil. The type SS material allows for adequate penetration of the helices into the hard/dense material without “spin-out”, i.e., loss of thrust of the helices in the soft/loose material.

The transition section adapts type SS helical lead sections to type RS plain extensions. Installation of this combination pile is the same as a standard helical pile. Table 37 provides the various standard transition couplers that are available along with their ratings. Special transition couplers, such as RS2875 to RS4500, are also available. Please contact your Chance® distributor for availability and delivery times.

A Registered Professional Engineer with suitable soil information should prepare the design.

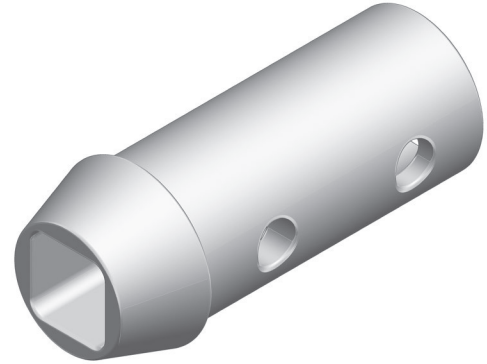

C1500896

PILE ASSEMBLY WITH RS CAST TRANSITION

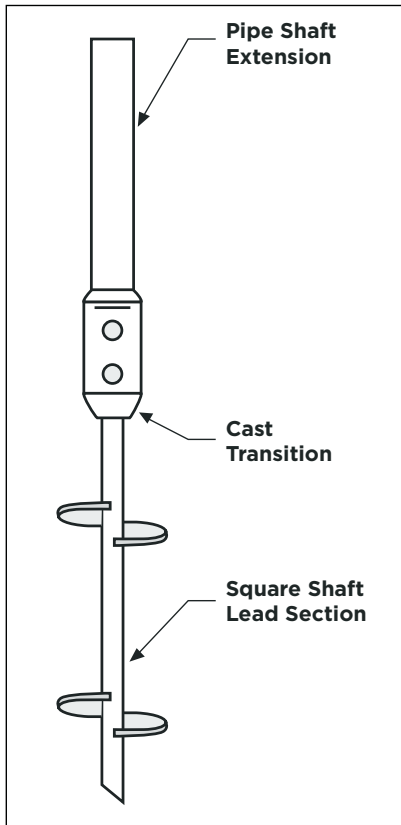

CAST TRANSITIONS, TABLE 39

Catalog No.	Description (SS = Square Shaft; RS = Round Shaft)			Weight	Torque Ratings
C1500896	SS5/SS150	to a	RS2875.203	7.8	7,000 ft-lbs
C1500895 †	SS175	to a	RS3500.300	13.0	11,000 ft-lbs
C1501365	SS175	to a	RS2875	10.3	Up to 8900 ft-lbs
C1500937	SS200	to a	RS3500.300	16.3	13,000 ft-lbs
C1101443	SS200	to a	RS4500	26	16,000 ft-lbs
C1101418	SS225	to a	RS4500	26	21,000 ft-lbs

† ICC-ES Building code listed - see page 2 for more information.

HELICAL PULLDOWN® MICROPILE

The Chance® Helical Pulldown® Micropile (HPM) is a method used to form a grout column around the shaft of a standard helical pile. The installation process can employ grout only (see Figure 1) or grout in combination with either steel or PVC casing (see Figure 2).

To begin the process, a helical pile is placed into the soil by applying torque to the shaft. The helical shape of the bearing plates creates a significant downward force that keeps the foundation advancing into the soil. After the lead section with the helical plates penetrates the soil, a lead displacement plate and extension plates are placed onto the shaft. Resuming torque on the assembly advances the helical plates and pulls the displacement plate downward, forcing soil outward to create a cylindrical void around the shaft. From a reservoir at the surface, a flowable grout immediately fills this void surrounding the shaft. Additional extensions and displacement plates are added until the helical bearing plates reach the minimum depth required or competent load-bearing soil. This displacement pile system does not require removing spoils from the site.

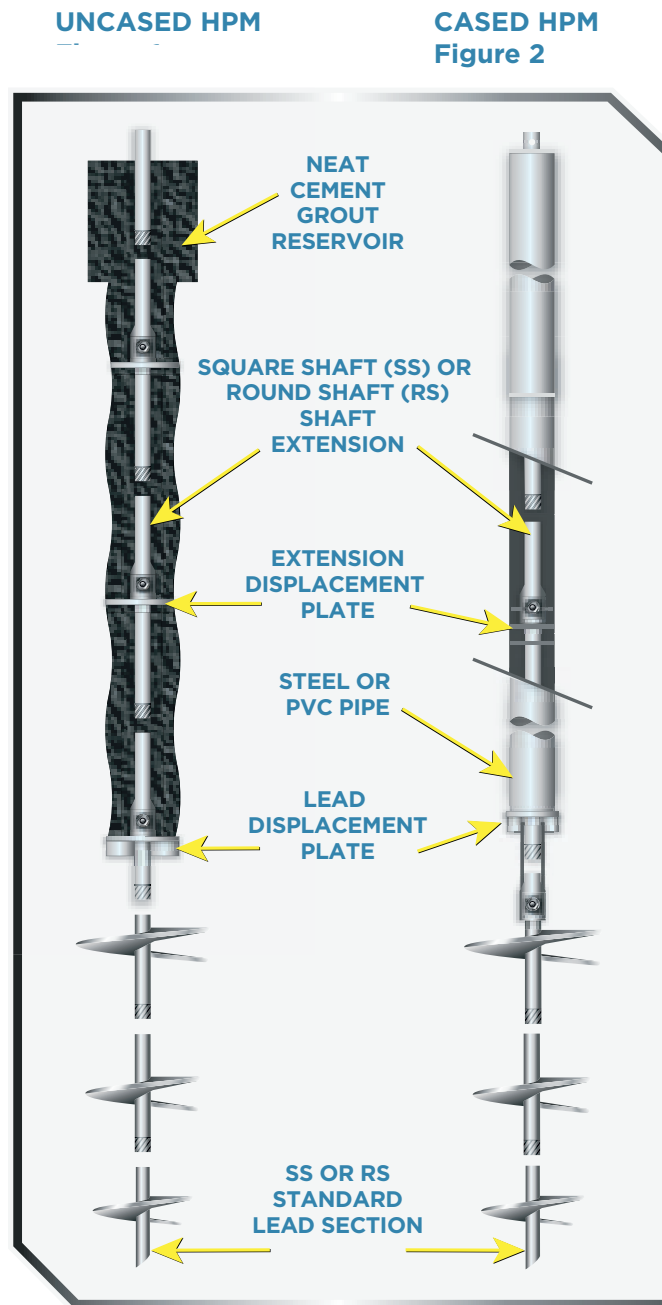

Displacement Plates for Uncased Grout Columns

LEAD DISPLACEMENT PLATES, TABLE 40

Catalog No.	Plate Dia. (in)	Product Series
T1500334	5	SS5/SS150
T1500335	7	SS5/SS150
C1501353	4	SS175
C1500383	5	SS175
C1500387	7	SS175
C1500389	8.5	SS175
C1500405	10	SS175
C1500391	7	SS200
C1500393	8.5	SS200
C1500395	10	SS200

EXTENSION DISPLACEMENT PLATES, TABLE 41

Catalog No.	Plate Dia. (in)	Product Series
C1500382	3.9	SS5/SS150
T1500330	5	SS5/SS150
T1500331	7	SS5/SS150
C1500384	5	SS175
C1500386	5.9	SS175
C1500388	7	SS175
C1500390	7.9	SS175
C1500406	10	SS175
C1500392	5.9	SS200
C1500394	7.9	SS200

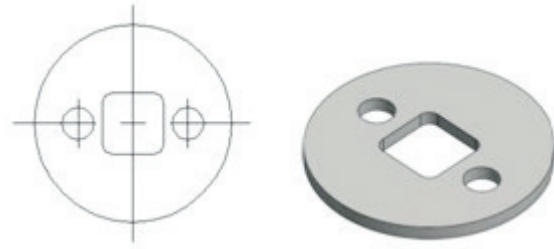
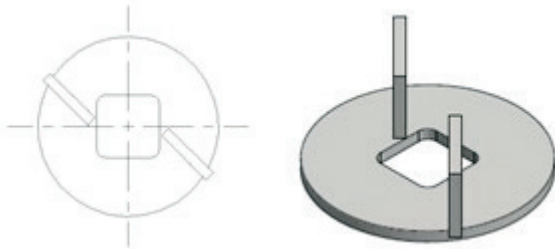

Displacement Plates for Cased Grout Columns

LEAD DISPLACEMENT PLATES, TABLE 42

Catalog No.	Plate Dia (in)	Casing Dia (in)	Product Series
T1500339	5	4	SS5/SS150
C1500424	7	6	SS175
C1500425	7	6	SS200

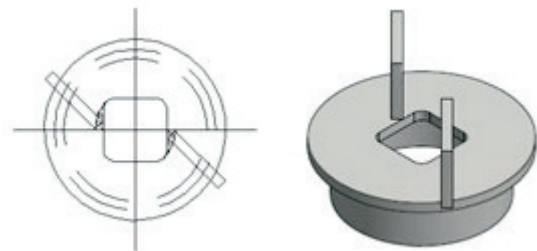

EXTENSION DISPLACEMENT PLATES, TABLE 43

Catalog No.	Plate Dia (in)	Casing Dia (in)	Product Series
T1500338	5	4	SS5/SS150
C1500426	7	6	SS175
C1500427	7	6	SS200

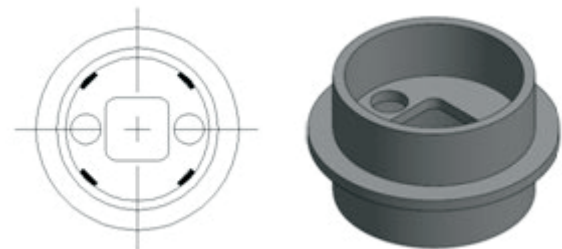

HPM Lead and Extension Displacement Assemblies for RS Helical Piles

LEAD DISPLACEMENT PLATES, TABLE 44

Catalog No.	Plate Dia (in)	Product Series
C1500966	6	RS2875
C1500967	6	RS3500
C1500972	8	RS3500
C1500980	6	RS4500
C1500981	8	RS4500

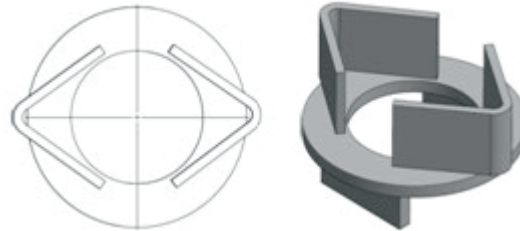

EXTENSION DISPLACEMENT PLATES, TABLE 45

Catalog No.	Plate Dia (in)	Product Series
C1500961	5.9	RS2875
C1500962	5.9	RS3500
C1500963	7.9	RS3500
C1500964	5.9	RS4500
C1500965	7.9	RS4500

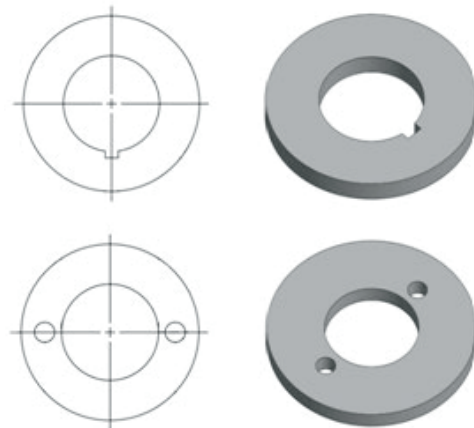

STEEL PIG DISPLACEMENT PLATES, TABLE 46

Catalog No.	Plate Dia (in)	Product Series
C1500989	7.13	RS2875
C1500993	7.13	RS3500
C1500994	9.13	RS3500
C1500995	7.13	RS4500
C1500996	9.13	RS4500

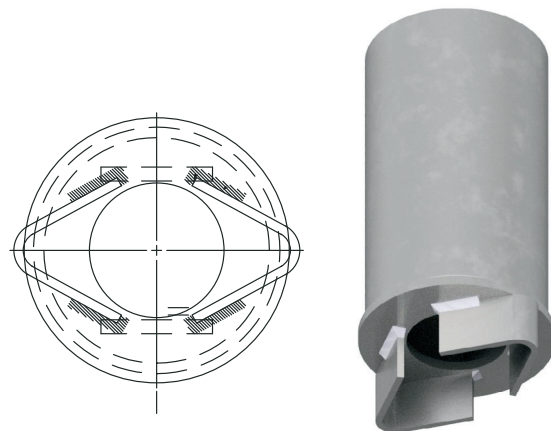

REMEDIAL REPAIR BRACKETS

C1500121 Standard Bracket and T-Pipe System

- Used with Chance® type SS5 & SS150, type RS2875.203, and type RS2875.276
- Use for lifts up to 4" (10 cm)
- System includes:
 - Foundation bracket
 - T-pipe
 - Hardware
- Order separately: two 5/8" (16 mm) diameter anchor bolts per pile as required.
- Standard finish is hot dip galvanized per ASTM A153.
- Ultimate mechanical strength of bracket body is 80,000 lbs (356 kN).
- Working mechanical strength of bracket body is 40,000 lbs (178 kN).

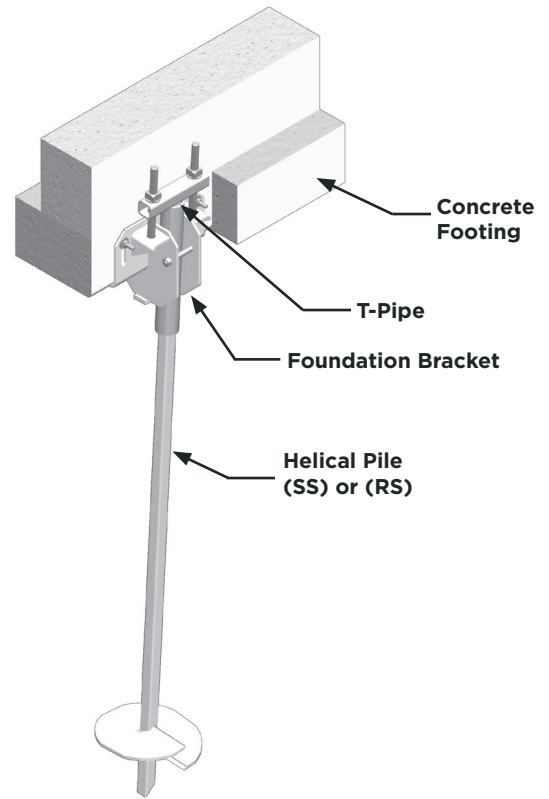

C1500121 + STANDARD BRACKET AND T-PIPE RATINGS, TABLE 47

Catalog No.	Ultimate Mechanical Strength ^{1,3} lbs (kN)	Pile Size in (mm)	Product Series	Max Working Capacity ^{2,3} per Product Series lbs (kN)	Features
C1500486 †	40,000 (178)	1-1/2 (38) Square	SS5/SS150	20,000 (89)	Lowest cost with square shaft
C1500487 †	80,000 (356)	1-1/2 (38) Square	SS5/SS150	20,000 (89) 25,000 (111)	Higher capacity with SS150
C2780001 †	40,000 (178)	2-7/8 (73) Round	RS2875.203	20,000 (89)	Lowest cost with round shaft
C2780002 †	80,000 (356)	2-7/8 (73) Round	RS2875.203	25,000 (111)	Higher capacity with stronger T-pipe
C2788011 †	80,000 (356)	2-7/8 (73) Round	RS2875.276	30,000 (133)	Higher capacity with RS2875.276
C2788012 †	40,000 (178)	2-7/8 (73) Round	RS2875.276	20,000 (89)	Higher capacity with RS2875.203

Notes:

1. Ultimate mechanical strength is for the bracket body and T-pipe combination.
2. The capacity of Chance helical pile systems is a function of many individual elements, including the capacity of the foundation, bracket, pile shaft, helix plate and bearing stratum, as well as the strength of the foundation-to-bracket connection, and the quality of the helical pile installation. The fifth column shows typical working capacities of the Chance helical pile system based upon maximum shaft exposure of 2 feet and soil strength having a minimum Standard Penetration Test (SPT) blow count "N" of 4. Actual capacities could be higher or lower depending on the above factors.
3. The ultimate capacity of the system, i.e., bracket, T-pipe, and pile shaft, can be increased to the pile shaft compression capacity limit as shown in the Technical Design Manual, provided the pile shaft is reinforced using a pipe sleeve or grout column. The maximum working capacity shall not be greater than one-half of the ultimate mechanical strength of the bracket and T-pipe combination given above.

† ICC-ES Building code listed - see page 2 for more information.

C1500299 Standard Bracket and T-Pipe System

- Used with Chance® type SS175
- Use for lifts up to 4" (10 cm)
- System includes:
 - Foundation bracket
 - T-pipe
 - Hardware
- Order separately: two 5/8" (16 mm) diameter anchor bolts per pile as required.
- Standard finish is hot dip galvanized per ASTM A153.
- Ultimate mechanical strength of bracket body is 80,000 lbs (356 kN).
- Working mechanical strength of bracket body is 40,000 lbs (178 kN).

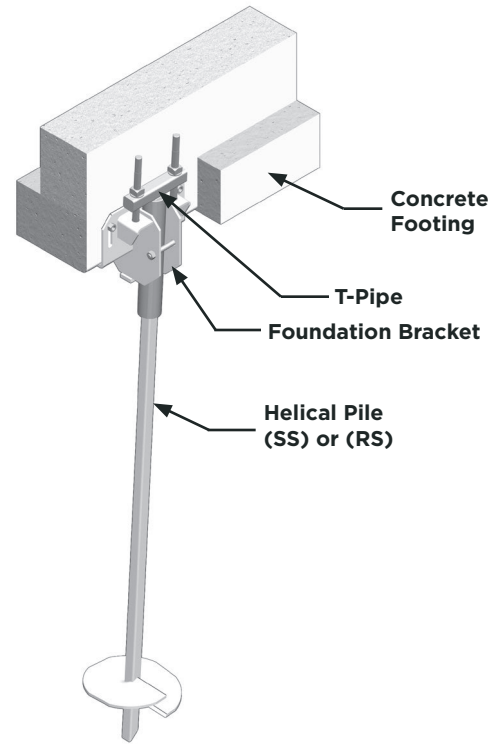

C1500299 + STANDARD BRACKET AND T-PIPE RATINGS, TABLE 48

Catalog No.	Ultimate Mechanical Strength ^{1,3} lbs (kN)	Pile Size in (mm)	Product Series	Max Working Capacity ^{2,3} per Product Series lbs (kN)	Features
C1500488 †	80,000 (356)	1-3/4 (38) Square	SS175	30,000 (133)	Lowest cost with Type SS175 product series

Notes:

1. Ultimate mechanical strength is for the bracket body and T-pipe combination.
2. The capacity of Chance helical pile systems is a function of many individual elements, including the capacity of the foundation, bracket, pile shaft, helix plate and bearing stratum, as well as the strength of the foundation-to-bracket connection, and the quality of the helical pile installation. The fifth column shows typical working capacities of the Chance helical pile system based upon maximum shaft exposure of 2 feet and soil strength having a minimum Standard Penetration Test (SPT) blow count "N" of 4. Actual capacities could be higher or lower depending on the above factors.
3. The ultimate capacity of the system, i.e., bracket, T-pipe, and pile shaft, can be increased to the pile shaft compression capacity limit as shown in the Technical Design Manual, provided the pile shaft is reinforced using a pipe sleeve or grout column. The maximum working capacity shall not be greater than one-half of the ultimate mechanical strength of the bracket and T-pipe combination given above.

† ICC-ES Building code listed - see page 2 for more information.

C1500147 Standard Bracket and T-Pipe System

- Used with Chance® type SS175, type SS200, and type RS3500.300
- Use for lifts up to 4" (10 cm)
- System includes:
 - Foundation bracket
 - T-pipe
 - Hardware
- Order separately: four 5/8" (16 mm) diameter anchor bolts per pile as required.
- Standard finish is hot dip galvanized per ASTM A153.
- Ultimate mechanical strength of bracket body is 120,000 lbs (534 kN).
- Working mechanical strength of bracket body is 60,000 lbs (267 kN).

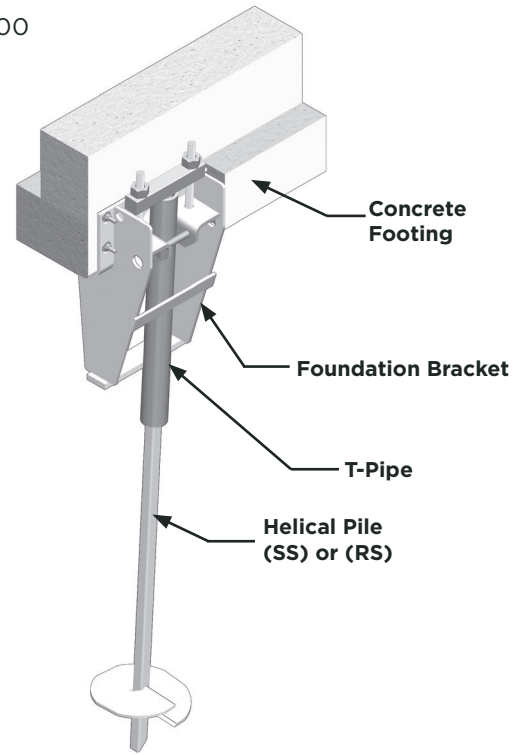

C1500147 † STANDARD BRACKET AND T-PIPE RATINGS, TABLE 49

Catalog No.	Ultimate Mechanical Strength ^{1,3} lbs (kN)	Pile Size in (mm)	Product Series	Max Working Capacity ^{2,3} per Product Series lbs (kN)	Features
C1500474 †	120,000 (534)	1-3/4 (44) Square	SS175	40,000 (178)	Lowest cost with square shaft
C1500508	120,000 (534)	2 (51) Square	SS200	50,000 (222)	Highest capacity with square shaft
C1500475 †	120,000 (534)	3-1/2 (89) Round	RS3500.300	50,000 (222)	Higher capacity with RS3500.300

Notes:

1. Ultimate mechanical strength is for the bracket body and T-pipe combination.
2. The capacity of Chance helical pile systems is a function of many individual elements, including the capacity of the foundation, bracket, pile shaft, helix plate and bearing stratum, as well as the strength of the foundation-to-bracket connection, and the quality of the helical pile installation. The fifth column shows typical working capacities of the Chance helical pile system based upon maximum shaft exposure of 2 feet and soil strength having a minimum Standard Penetration Test (SPT) blow count "N" of 4. Actual capacities could be higher or lower depending on the above factors.
3. The ultimate capacity of the system, i.e., bracket, T-pipe, and pile shaft, can be increased to the pile shaft compression capacity limit as shown in the Technical Design Manual, provided the pile shaft is reinforced using a pipe sleeve or grout column. The maximum working capacity shall not be greater than one-half of the ultimate mechanical strength of the bracket and T-pipe combination given above.

† ICC-ES Building code listed - see page 2 for more information.

PSAC1500499 Low Profile Bracket and T-Pipe System

- Used with Chance® type SS5 & SS150, type RS2875.203, and type RS2875.276
- Use for lifts up to 4" (10 cm)
- System includes:
 - Foundation bracket
 - T-pipe
 - Hardware
- Order separately: two 1/2" (13 mm) diameter anchor bolts per pile as required.
- Standard finish is hot dip galvanized per ASTM A153.
- Ultimate mechanical strength of bracket body is 30,000 lbs (133 kN).
- Working mechanical strength of bracket body is 15,000 lbs (67 kN).

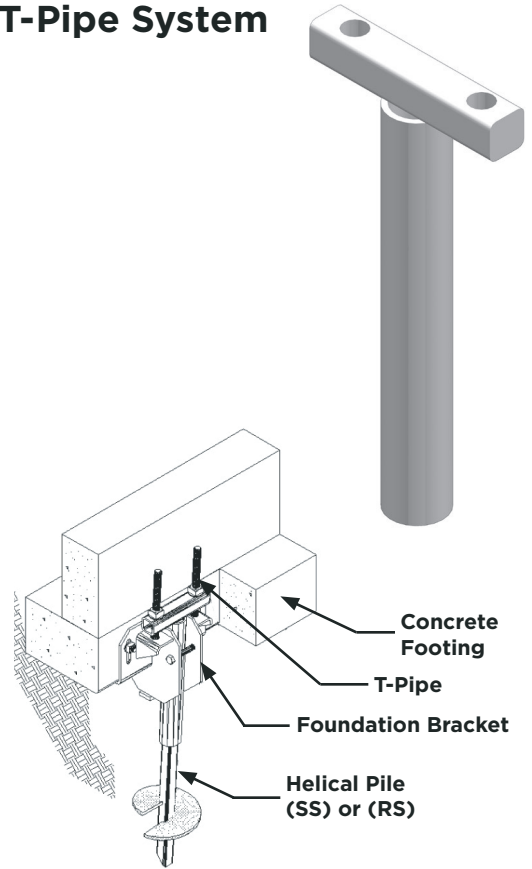

PSAC150049 LOW PROFILE BRACKET AND T-PIPE RATINGS, TABLE 50

Catalog No.	Ultimate Mechanical Strength ^{1,3} lbs (kN)	Pile Size in (mm)	Product Series	Max Working Capacity ^{2,3} per Product Series lbs (kN)	Features
PSAC1500503	30,000 (133)	1-1/2 (38) Square	SS5/SS150	15,000 (67)	Lowest cost with SS5 product series
PSAC2780003	30,000 (133)	2-7/8 (73) Round	RS2875.203	15,000 (67)	Lowest cost with RS2875.203 product series

Notes:

1. Ultimate mechanical strength is for the bracket body and T-pipe combination.
2. The capacity of Chance helical pile systems is a function of many individual elements, including the capacity of the foundation, bracket, pile shaft, helix plate and bearing stratum, as well as the strength of the foundation-to-bracket connection, and the quality of the helical pile installation. The fifth column shows typical working capacities of the Chance helical pile system based upon maximum shaft exposure of 2 feet and soil strength having a minimum Standard Penetration Test (SPT) blow count "N" of 4. Actual capacities could be higher or lower depending on the above factors.
3. The ultimate capacity of the system, i.e., bracket, T-pipe, and pile shaft, can be increased to the pile shaft compression capacity limit as shown in the Technical Design Manual, provided the pile shaft is reinforced using a pipe sleeve or grout column. The maximum working capacity shall not be greater than one-half of the ultimate mechanical strength of the bracket and T-pipe combination given above.

Direct Jack (DJ) Underpinning Bracket

- Used with Chance® type SS5 & SS150, SS175, RS2875.276, and RS3500.300
- Use for lifts up to 4" (10 cm)
- System includes:
 - Foundation bracket
 - T-pipe
 - Two thread bar nuts
- Order separately: two 1/2" (13mm) diameter concrete anchor bolts per pile as required.
- Standard finish is hot dipped galvanized per ASTM A153.
- Material specifications:
 - Bracket Body: 1/2" thick steel per ASTM A36 latest rev. T-pipe.
 - Pipe: steel pipe per ASTM A500 latest rev.
 - Lifting studs: Williams form #11 Grade 90.



C1500738

DIRECT JACK (DJ) UNDERPINNING BRACKETS, TABLE 51

Catalog No.	Ultimate Mechanical Strength ^{1,3} lbs (kN)	Pile Size in (mm)	Max Working Capacity ^{2,3} per Product Series lbs (kN)	Features
C1500738 †	70,000 (356)	1-1/2" (38) Square	35,000 (133)	Lowest cost
C1500733	100,000 (445)	1-3/4" (44) Square	50,000 (222)	Highest capacity
C1500840 †	72,000 (320)	2-7/8" (73) Round	36,000 (160)	
C1500841 †	91,000 (405)	3-1/2" (89) Round	45,000 (202)	

Notes:

1. Ultimate mechanical strength is for the bracket body and T-pipe combination.
 2. The capacity of Chance helical pile systems is a function of many individual elements, including the capacity of the foundation, bracket, pile shaft, helix plate and bearing stratum, as well as the strength of the foundation-to-bracket connection, and the quality of the helical pile installation. The fifth column shows typical working capacities of the Chance helical pile system based upon maximum shaft exposure of 2 feet and soil strength having a minimum Standard Penetration Test (SPT) blow count "N" of 4. Actual capacities could be higher or lower depending on the above factors.
 3. The ultimate capacity of the system, i.e., bracket, T-pipe, and pile shaft, can be increased to the pile shaft compression capacity limit as shown in the Technical Design Manual, provided the pile shaft is reinforced using a pipe sleeve or grout column. The maximum working capacity shall not be greater than one-half of the ultimate mechanical strength of the bracket and T-pipe combination given above.
- † ICC-ES Building code listed - see page 2 for more information.

C1500239 Light Duty / Porch Bracket

This bracket is used to raise the concrete slab edge or non-load bearing wall using a screw lift system. The assembly consists of the light duty porch bracket and helical pile (order helical pile separately).

- Ultimate mechanical strength = 10,000 lbs (44 kN)
- Maximum working capacity = 5,000 lbs (22 kN)
- Standard finish is hot dip galvanized per ASTM153.
- Use only with SS5 and SS150 piles

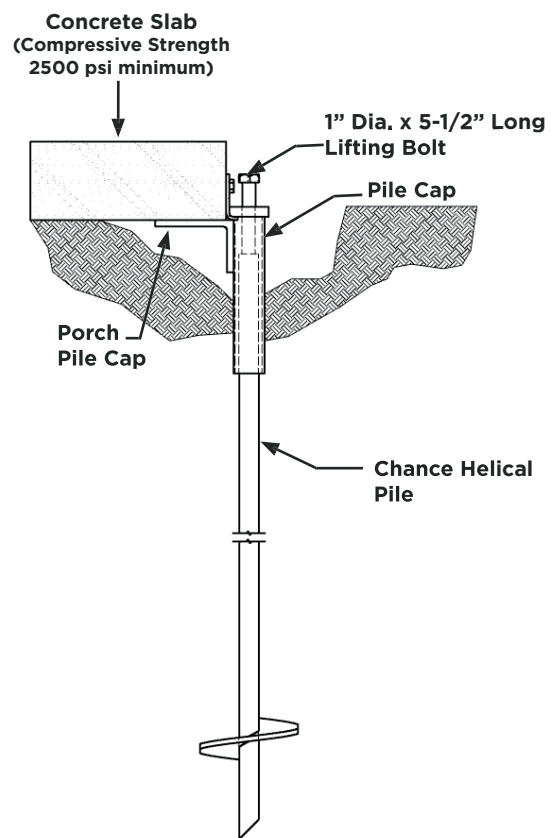
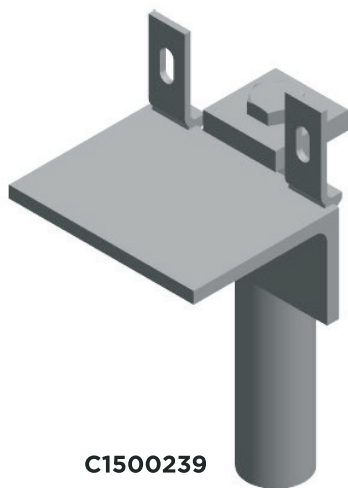

T1500085 / C1501441 Concrete Slab Brackets

This bracket is used to raise the concrete slab using a screw lift system through the slab. The assembly consists of the screw lift slab bracket and helical pile (order helical pile separately).

- Ultimate mechanical strength = 10,000 lbs (44 kN)
- Maximum working capacity = 5,000 lbs (22 kN)
- Maximum lifting capacity = 7,500 lbs (33 kN)
- Standard finish is hot dip galvanized per ASTM153.

STANDARD PILE SIZE(S):

- **T1500085** to be used with only SS5 and SS150 piles
- **C1501441** to be used with only RS2875 piles

NOTE: Standard access hole: 6"-8" dia. for SS piles.

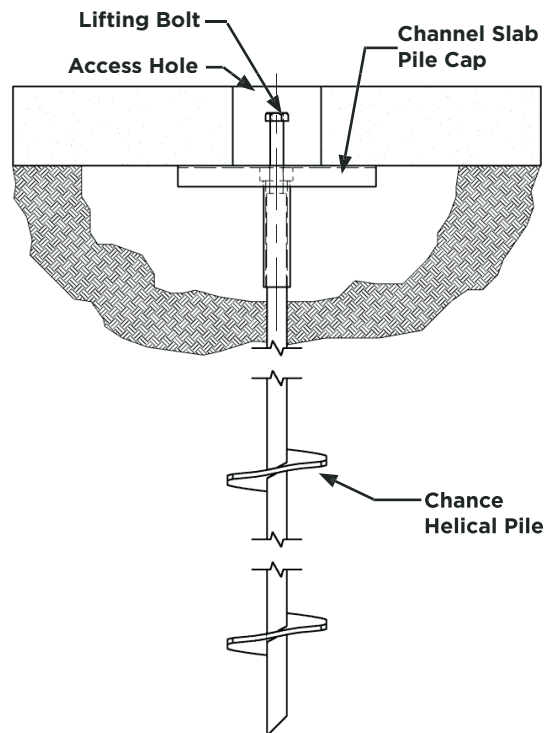
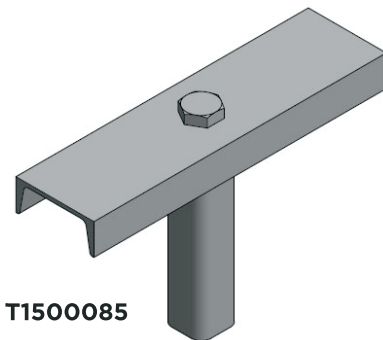

Walkway Support Brackets

These brackets are used to connect timbers or girder beams to helical piles. The split bracket design is more universal because beam thickness or tolerance is not a problem. Both of these brackets fit over an SS5 or SS150 square shaft and inside an RS2875.203 round shaft.

Types of Walkway Brackets:

- **C1100682** and **C1100736** brackets are used only with SS5 and SS150 piles.
- **C1100936** and **C1100925** brackets are used only with RS2875 piles.

Standard finish is hot dipped galvanized per ASTM A153.

For different size shafts, mounting holes, or special finishes please contact your Chance distributor for availability.

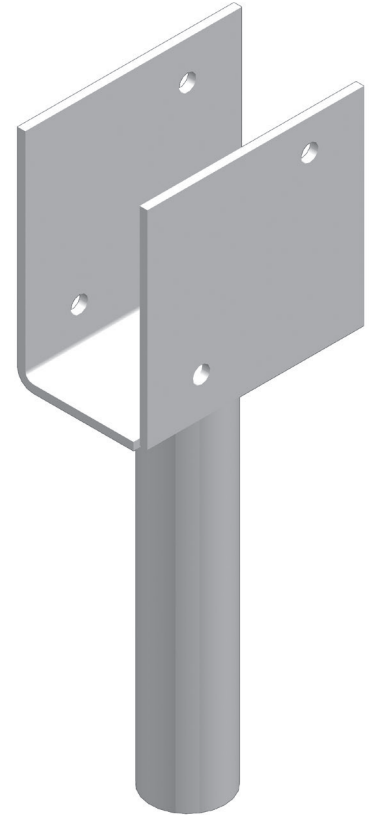

C1100682 WALKWAY BRACKET

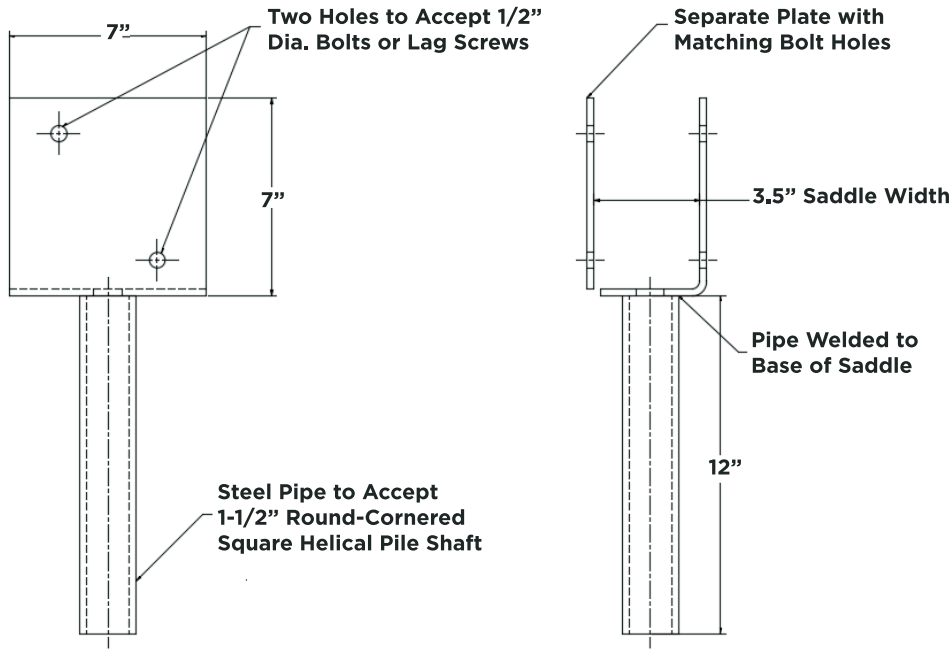

C1100936 WALKWAY BRACKET

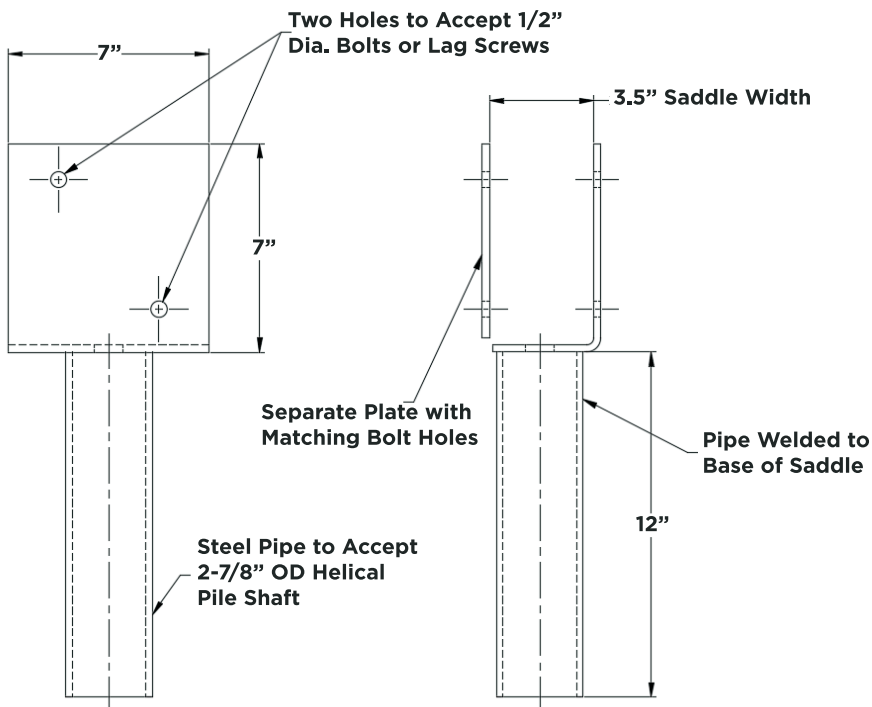

C1100736 WALKWAY BRACKET

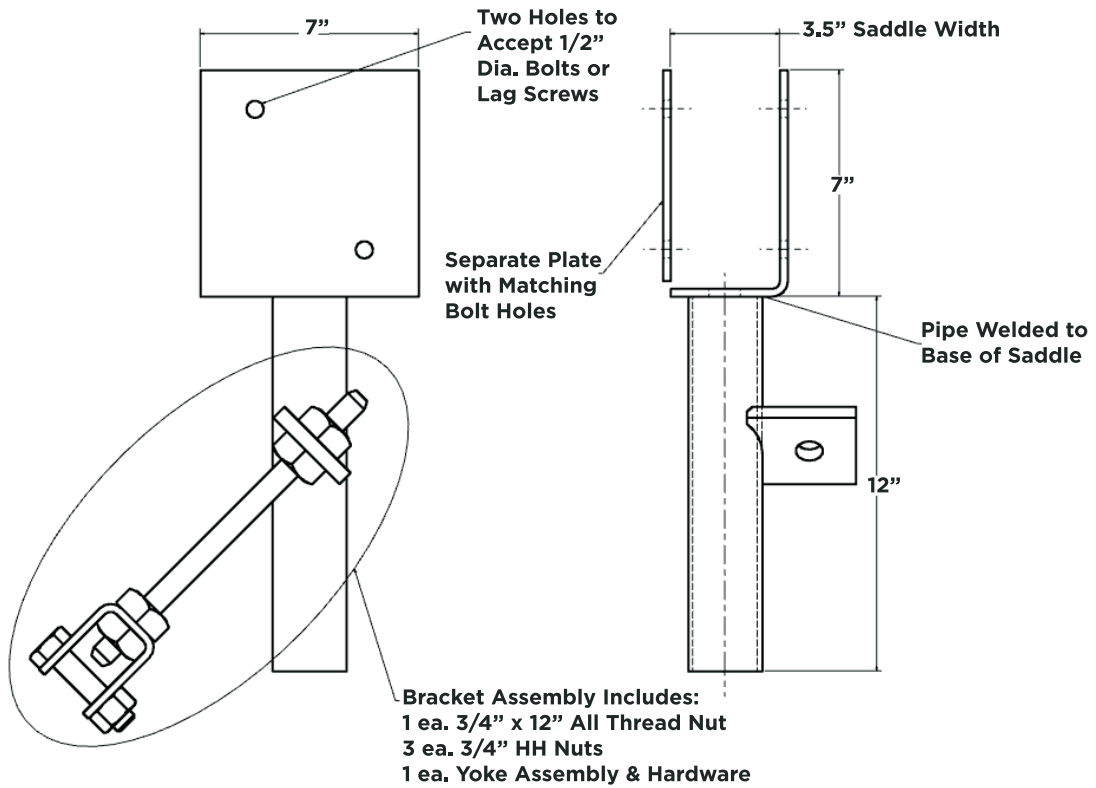

C1100925 WALKWAY BRACKET

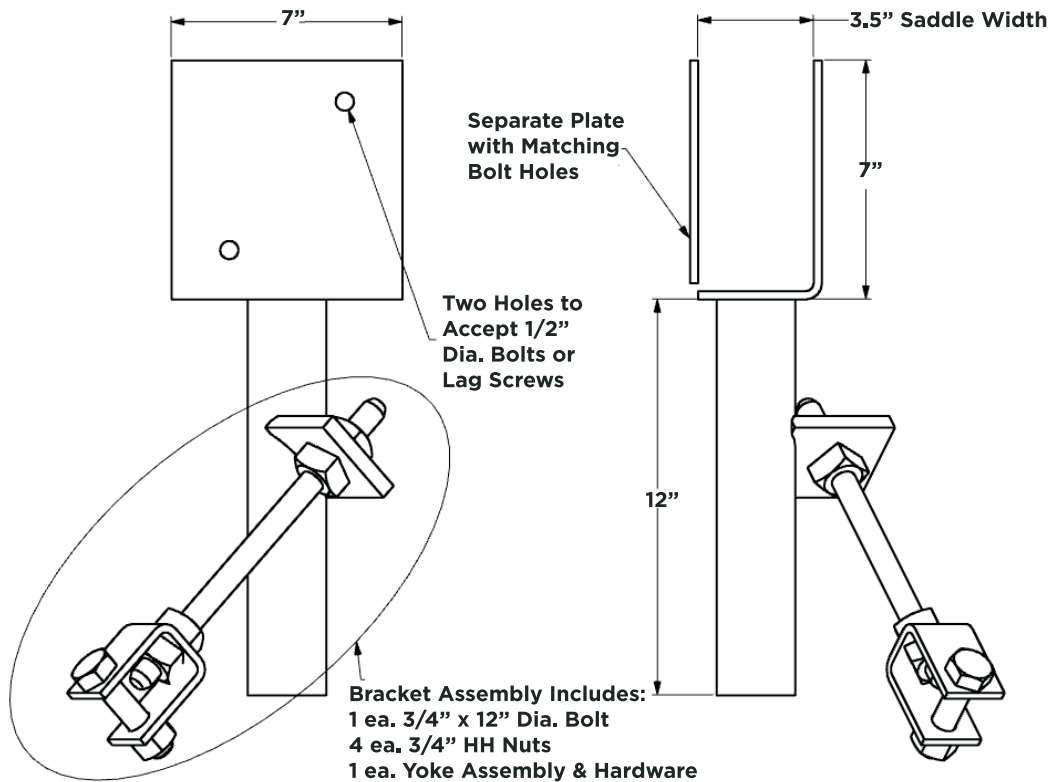

WALL ANCHOR SYSTEM

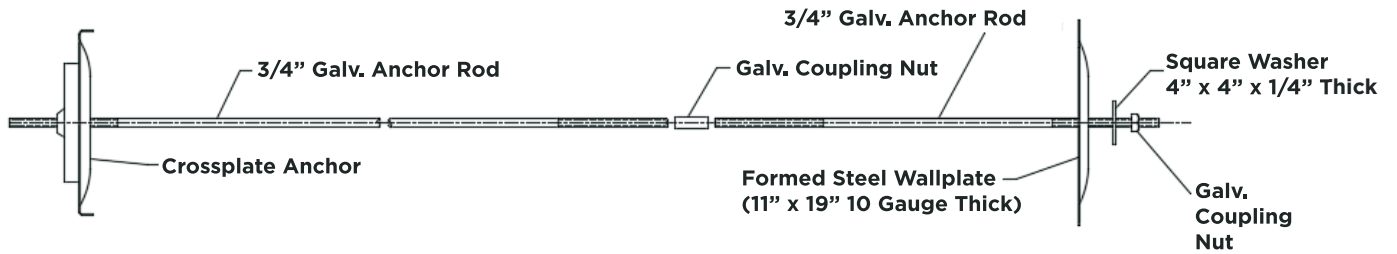

WILLIAMS FORM WALL PLATE AND TRANSITION KITS (AVAILABLE ONLY IN HDG), TABLE 52

Catalog No.	Description	Weight (lbs)
C1500633	SS125 Transition Assembly Kit	19.1

WALL ANCHOR KITS AND COMPONENTS, TABLE 53

Catalog No.	Description (in)	C1500032 20" Threaded Bar Adapter	12698 7' x 1-1/4" Extension	E1500088 Plate and Washer Assembly	E1500079 8" Helix	E1500252 10" Helix	E1500254 12" Helix
T1500080	(8) Kit	X	X	X	X		
T1500253	(10) Kit	X	X	X		X	
T1500255	(12) Kit	X	X	X			X

"X" = Included in Kit.

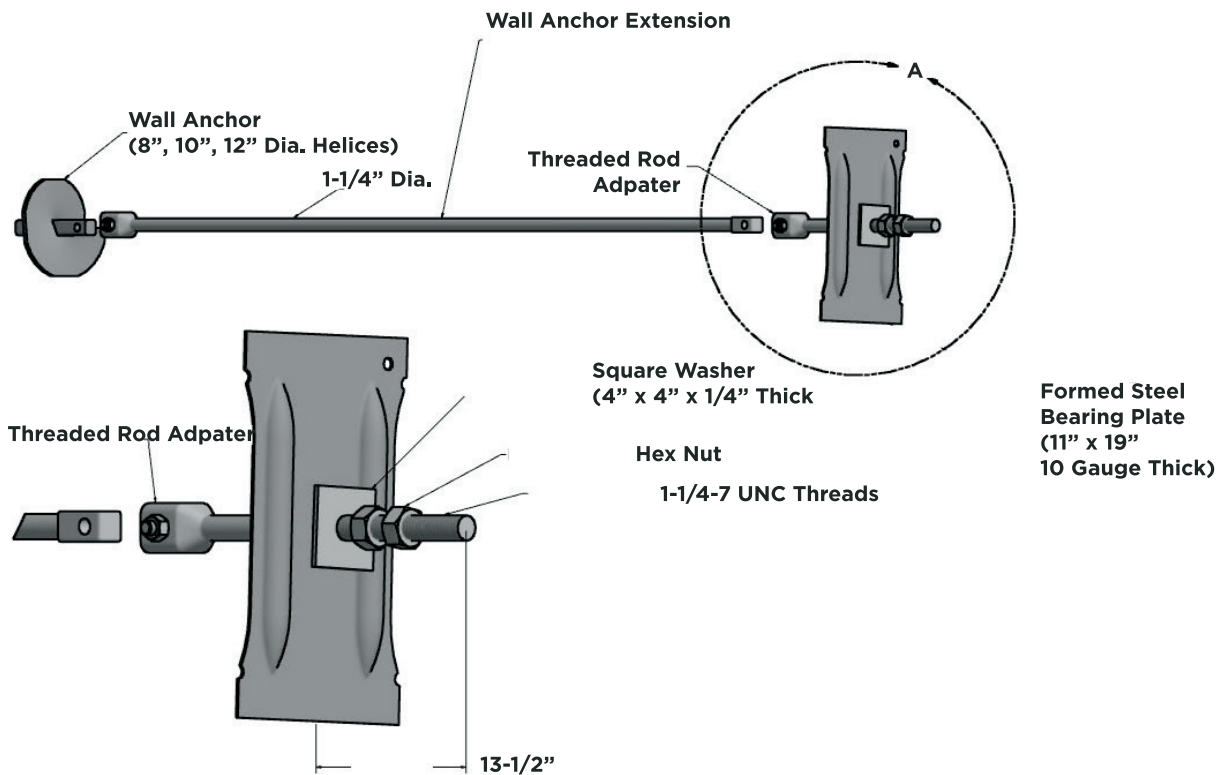

OPTIONAL WALL ANCHOR COMPONENTS, TABLE 54

Catalog No.	Description	Weight (lbs)
T1500447	4' Threaded Adapter	19
12696	3.5' x 1-1/4" Extension	20
12697	5' x 1-1/4" Extension	28

KITS, TABLE 55

Catalog No.	Crossplate Anchor		Wallplate		Anchor Rod		Weight
	Size (in)	Description	Size (in)	Description	Rod Size	Accessories	
T1500362	20	Galvanized	19	Galvanized w/ washer	9' x 3/4"	2 nuts	39.2
T1500363	20	Clear-coat	19	Clear-coat w/ washer	9' x 3/4"	2 nuts	37.8
T1500364	20	Galvanized	19	Galvanized w/ washer	9' x 3/4" 4-1/2' x 3/4"	2 nuts 1 Nut, 1 Coupling	46.2
T1500366	20	Galvanized	19	Galvanized w/ washer	4-1/2' x 3/4" 4-1/2' x 3/4"	1 Nut, 1 Coupling 1 Nut	40.2
T1500367	20	Clear-coat	19	Clear-coat w/ washer	4-1/2' x 3/4" 4-1/2' x 3/4"	1 Nut, 1 Coupling 1 Nut	38.8

ACCESSORIES, TABLE 56

Catalog No.	Description	Weight (lbs)
T1500348	Four each: Galv washers, Galv square nuts, and Galv couplings (all for 3/4" rod)	5.0
T1500349	9' x 3/4" Galv rod w/ 18" of thread on both ends	13.5
T1500350	4-1/2' x 3/4" Galv rod w/ 18" of thread on both ends	6.5
T1500351	4-1/2' x 3/4" Rod, all-thread	7.4
T1500372	25" Galv wallplate w/ galv washer	16.8
T1500373	25" Clear-coated wallplate w/ clear-coated washer	18.0
T1500374	24" Galv crossplate anchor	34.0

TERMINATION DEVICES

Specifying exactly what you need is simple with Chance® helical foundation support products. A variety of standard accessories and special termination devices are offered depending on the project and application. This section illustrates some of our standard termination devices along with their mechanical ratings. If your project requires a special termination device, please contact your Chance distributor.

New Construction Pile Caps

The Chance new construction pile caps are designed for use with Chance type square shaft (SS) and round shaft (RS) helical piles and for embedment in cast-in-place concrete foundations. For preliminary design, guidelines for reinforced pile caps refer to Section 4 of the Technical Design Manual, 5th Edition.

RS & SS SHAFT: COMPRESSION ONLY

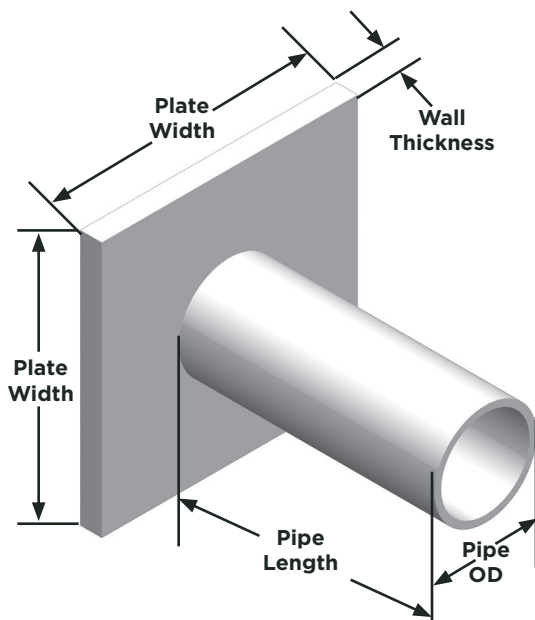

SS SHAFT: COMPRESSION AND UPLIFT

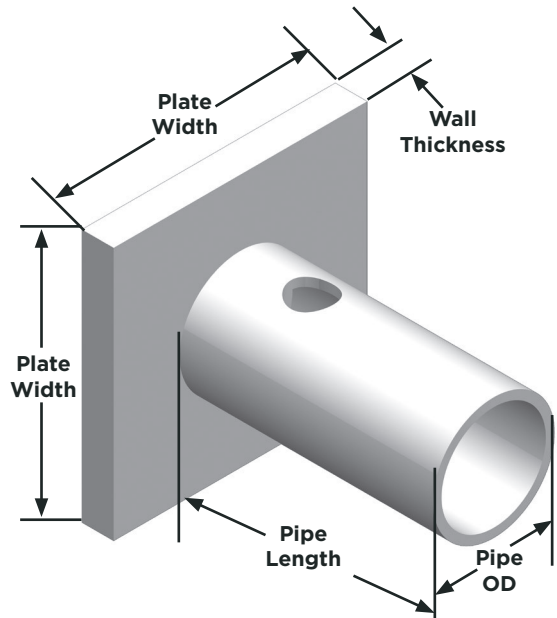

SS SHAFT: EQUAL COMPRESSION AND UPLIFT CAPACITY

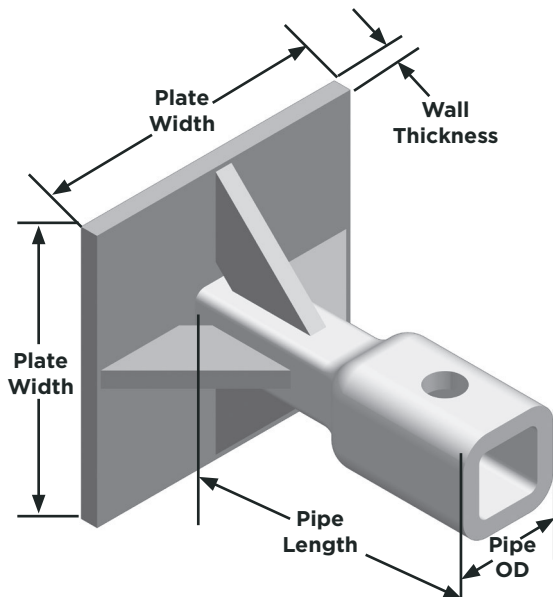

RS SHAFT: COMPRESSION AND UPLIFT

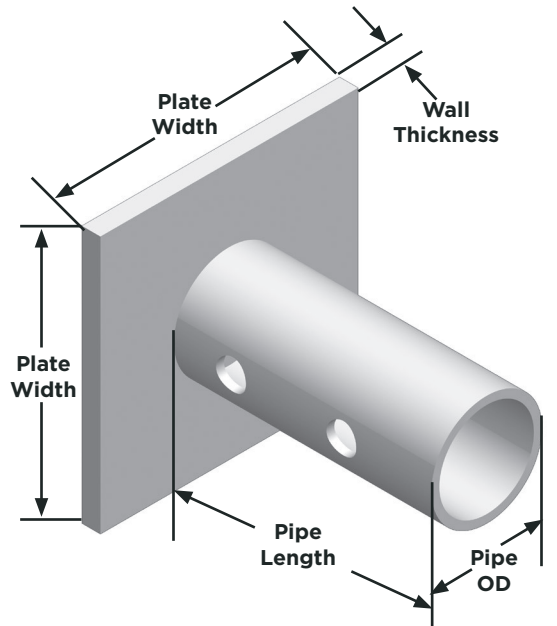

NEW CONSTRUCTION PILE CAPS AND RATINGS, TABLE 57

Catalog No.	Fits Shaft Size	Plate Size			Pipe Dimensions			# of Holes	Bolt Diameter (in)	Working Load Rating (kip)	
		Length (in)	Width (in)	Thickness (in)	OD (in)	Wall Thickness (in)	Length (in)			Compression	Uplift
C1500781 †	RS2875	7	7	1/2	3.5	0.216	6	0	N/A	36	N/A
C1500797 †	RS2875	7	7	1/2	3.5	0.216	7	2	3/4	36	36
C1501357 †	RS3500	8	8	1/2	4.5	0.337	7	3	3/4	60	52
C1501356 †	RS3500	8	8	3/4	4.5	0.337	6	0	N/A	60	N/A
C1500782	RS3500	10	10	1/2	4.5	0.337	6	0	N/A	50	N/A
C1500798	RS3500	10	10	1/2	4.5	0.337	7	3	3/4	50	50
C1500783	RS4500	12	12	1/2	5.56	0.375	6	0	N/A	70	N/A
C1500799	RS4500	12	12	1/2	5.56	0.375	7	2	1	70	70
C1072726 †	RS4500	10	10	3/4	5.56	.375	7	0	N/A	97	N/A
C1072727 †	RS4500	10	10	3/4	5.56	.375	7	2	1	96.9	70.5
C1500458 †	SS5/ SS150	6	6	1/2	2.38	0.154	6	0	N/A	40	N/A
*C1500465 †	SS5/ SS150	6	6	1/2	2.38	0.154	6	1	3/4	40	20
C1500777 †	SS5/ SS150	7	7	1/2	2.5	0.154	6	0	N/A	35	N/A
C1500793 †	SS5/ SS150	7	7	1/2	2.5	0.154	6	1	3/4	35	23
C1500821	SS150	7	7	1/2	2.4	0.45	5.5	1	3/4	35	35
C1500459 †	SS175	6	6	3/4	2.88	0.203	6	0	N/A	60	N/A
*C1500467 †	SS175	6	6	3/4	2.88	0.203	6	1	7/8	60	30
C1500822	SS175	8	8	1/2	2.86	0.555	10	1	7/8	52.5	50
C1500778 †	SS175	8	8	1/2	2.88	0.203	6	0	N/A	52.5	N/A
C1500794 †	SS175	8	8	1/2	2.88	0.203	6	1	7/8	52.5	37
C1500823	SS200	12	12	1/2	3.3	0.65	10	1	1 1/8	75	75
C1500779	SS200	12	12	1/2	3.5	0.3	6	0	N/A	75	N/A
C1500795	SS200	12	12	1/2	3.5	0.3	6	1	1 1/8	75	45
C1500780	SS225	12	12	1/2	3.5	0.216	6	0	N/A	100	N/A
C1500796	SS225	12	12	1/2	3.5	0.216	6	1	1 1/4	100	40
C1500824	SS225	12	12	1/2	3.62	0.685	10.75	1	1 1/4	100	100

NOTE: All New Construction Caps are not galvanized. Add "G" to standard catalog number to order galvanized.

*Bolt and nut not provided.

† ICC-ES Building code listed - see page 2 for more information.

Chance Foundation Solutions |  A Hubbell brand

www.chancefoundationsolutions.com

©2024 Hubbell Incorporated. All rights reserved.

Hubbell, the Hubbell logo and its affiliate logos are registered trademarks owned by Hubbell Incorporated. All third-party trademarks are property of their respective owners. Because Hubbell has a policy of continuous product improvement, we reserve the right to change design and specifications without notice.

Printed in the U.S.A. | CA04140E | 06/2024