

# SS125 HELICAL PIERS AND ANCHORS

TORQUE STRENGTH RATING-4,000 FT-LB  
 ULTIMATE CAPACITY\* (TENSION/COMPRESSION)-40 KIP  
 \*BASED ON A TORQUE FACTOR (K<sub>t</sub>)=10  
 SINGLE HELIX ULTIMATE STRENGTH-30 KIP  
 ULTIMATE TENSION STRENGTH (COUPLING BOLT)-50 KIP

LEAD SECTION					
CAT. NO.	"A"	"B"	"C"	"D"	"F"
C1500545	62.75"	8"			59.5"
C1500546	62.75"	10"			59.5"
C1500547	62.75"	12"			59.5"
C1500548	62.75"	8"	10"		35.5"
C1500549	62.75"	10"	12"		29.5"
C1500550	62.75"	6"	8"	10"	18.0"
C1500551	62.75"	8"	10"	12"	7.0"
C1500552	81.75"	10"	12"	14"	13.0"

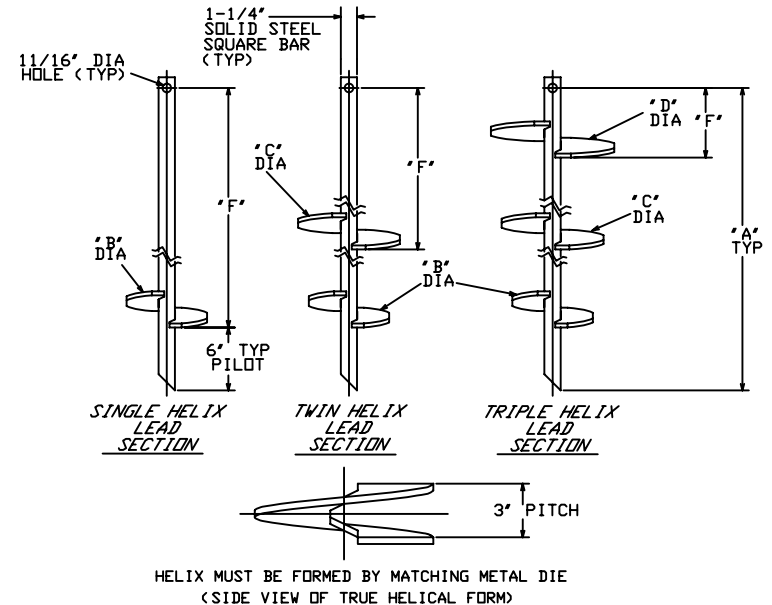
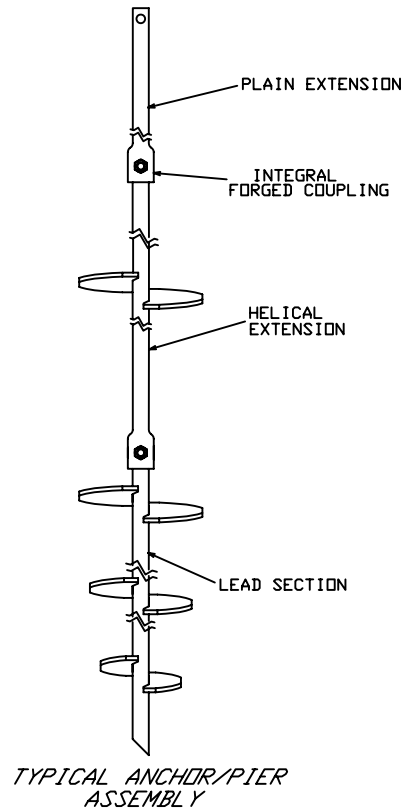

## -NOTES-

- HOT DIP GALVANIZED PER ASTM A153-(LATEST REV.)
- LEAD AND EXTENSION SECTION AND PILOT POINT LENGTHS ARE NOMINAL.
- SHAFT MATERIAL-HOT ROLLED ROUND-CORNERED SQUARE (RCS) SOLID STEEL BARS PER ASTM A29; MINIMUM YIELD STRENGTH=90 KSI.
- HELIX MATERIAL-HOT ROLLED LOW CARBON STEEL SHEET, STRIP, OR PLATE PER ASTM A572, OR A1018, OR A656; MINIMUM YIELD STRENGTH=50 KSI; 3/8" THICK.
- COUPLING BOLTS: 5/8" DIAMETER X 3" LONG HEX HEAD PER ASTM A325 TYPE 1.
- NOMINAL SPACING BETWEEN HELICAL PLATES IS THREE TIMES THE DIAMETER OF THE LOWER HELIX.
- MANUFACTURER TO HAVE IN EFFECT INDUSTRY RECOGNIZED WRITTEN QUALITY CONTROL FOR ALL MATERIALS AND MANUFACTURING PROCESSES.
- ALL WELDING TO BE DONE BY WELDERS CERTIFIED UNDER SECTION 5 OF THE AWS CODE D1.1.
- ALL HELIX HAVE A SHARPENED LEADING EDGE.
- REFER TO DRAWING SA1500553 FOR PLAIN EXTENSIONS AND TERMINATIONS.

CHANCE®			
	SS125 LEADS AND HELICAL EXTENSIONS		
CONFIDENTIAL: THIS DRAWING AND ITS CONTENTS ARE CONFIDENTIAL AND THE EXCLUSIVE PROPERTY OF HUBBELL POWER SYSTEMS, INC. NO PUBLICATION, DISTRIBUTION OR COPIES MAY BE MADE WITHOUT THE PRIOR WRITTEN CONSENT OF HUBBELL POWER SYSTEMS, INC. HUBBELL POWER SYSTEMS UNPUBLISHED ALL RIGHTS RESERVED UNDER THE COPYRIGHT LAWS.	SIZE A	DWG NO. SA1500545	REV -
DO NOT SCALE THIS DRAWING	DRN BY LMM	DATE 05/19/08	SHEET 1 OF 1