

SS5 EXTENSIONS

TORQUE STRENGTH RATING - 5,500 FT-LB
 ULTIMATE CAPACITY (TENSION/COMPRESSION)-55 KIP
 * BASED ON A TORQUE FACTOR (Kt)=10
 ULTIMATE TENSION STRENGTH (COUPLING BOLT)-70 KIP

EXTENSION		
CAT. NO.	"A"	ICC-ES LISTED †
C150-0047	37-3/4"	X
C150-0008	57-1/2"	X
C150-0009	80-1/2"	X
C150-0048	120"	X
C150-0032	20"	
C114-0009	11"	

† ICC-ES LISTINGS FORMERLY ICBO, SBCCI, AND BOCA.

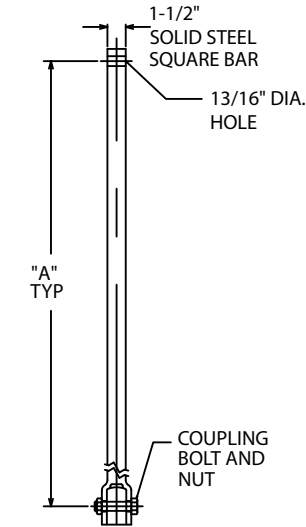

PLAIN EXTENSION

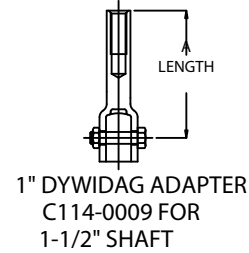

1" DYWIDAG ADAPTER
 C114-0009 FOR
 1-1/2" SHAFT

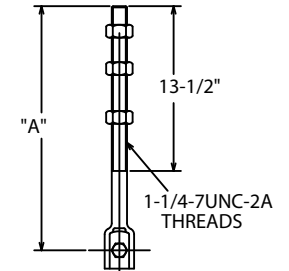

THREADED ADAPTER
 C150-0032 FOR
 1-1/2" SHAFT

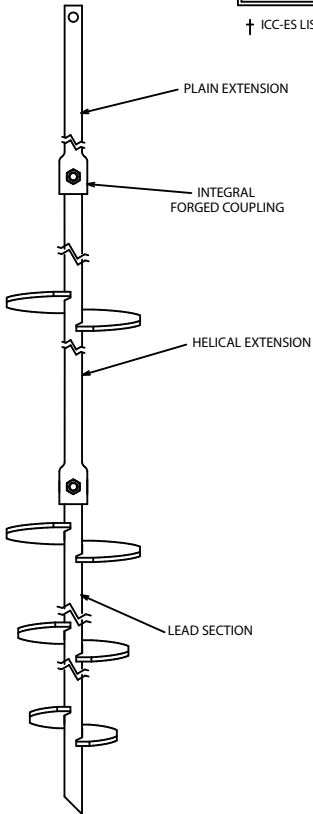

TYPICAL ANCHOR/PIER ASSEMBLY

-NOTES-

- HOT DIP GALVANIZED PER ASTM A153-(LATEST REV.)
- LEAD AND EXTENSION SECTION AND PILOT POINT LENGTHS ARE NOMINAL.
- SHAFT MATERIAL-HOT ROLLED ROUND-CORNERED-SQUARE (RCS) SOLID STEEL BARS PER ASTM A29; MINIMUM YIELD STRENGTH=70 KSI.
- COUPLING BOLTS: 3/4" DIAMETER X 3" LONG HEX HEAD PER ASTM A320 GRADE L7.
- MANUFACTURER TO HAVE IN EFFECT INDUSTRY RECOGNIZED WRITTEN QUALITY CONTROL FOR ALL MATERIALS AND MANUFACTURING PROCESSES.
- ALL WELDING TO BE DONE BY WELDERS CERTIFIED UNDER SECTION 5 OF THE AWS CODE D1.1.
- SEE ICC EVALUATION SERVICE INC., EVALUATION REPORT NO. ER-5110 FOR ALLOWABLE VALUES AND/OR CONDITIONS OF USE CONCERNING MATERIAL PRESENTED IN THIS DOCUMENT.
- REFER TO SA150-0001 DRAWING FOR LEAD SECTIONS AND HELICAL EXTENSIONS.

ICC-ES LISTED
 RR 94-27

ICC-ES LISTED
 ER-5110

ICC-ES LISTED
 ER-9504

CHANCE			
CONFIDENTIAL: THIS DRAWING AND ITS CONTENTS ARE CONFIDENTIAL AND THE EXCLUSIVE PROPERTY OF HUBBELL POWER SYSTEMS. NO PUBLICATION, DISTRIBUTION OR COPIES MAY BE MADE WITHOUT THE WRITTEN CONSENT OF HUBBELL POWER SYSTEMS. HUBBELL POWER SYSTEMS UNPUBLISHED. ALL RIGHTS RESERVED UNDER THE COPYRIGHT LAWS.			
TITLE		SS5 EXTENSIONS	
SIZE	DWG NO.	CAT / PART / ASSY NO.	REV
SC	SA150-0047	SEE CHART	---
DO NOT SCALE THIS DRAWING	DRN BY	KSH	DATE 4/25/05 SHEET 2/2